

**BLUEFIN**  
— FITNESS —

**BLADE AQUA M-1**  
WATER RESISTANCE ROWER

**INSTRUCTION MANUAL**  
DE BEDIENUNGSANLEITUNG  
ES MANUAL DE INSTRUCCIONES  
FR GUIDE D'UTILISATION  
IT MANUALE DELLE ISTRUZIONI  
NL HANDLEIDING

# BLADE AQUA



M-1 WATER RESISTANCE ROWER

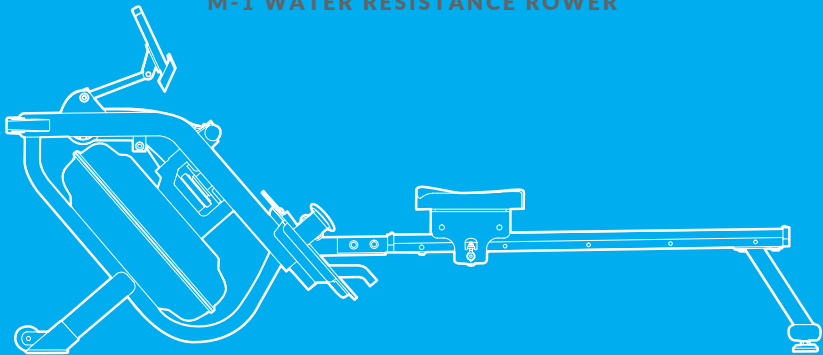



## WELCOME TO THE BLUEFIN FITNESS COMMUNITY

DEAR CUSTOMER

THANK YOU FOR CHOOSING THE BLUEFIN FITNESS BLADE AQUA M-1 ROWING MACHINE. TO ENSURE YOU GET THE MOST OUT OF YOUR NEW ROWER, PLEASE ENSURE THAT ALL PERSONS USING THE EQUIPMENT READ AND UNDERSTAND THE FOLLOWING MANUAL CAREFULLY BEFORE USE.

BLUEFIN FITNESS ASSUMES NO LIABILITY FOR DAMAGES CAUSED BY IMPROPER USE OR INCORRECT OPERATION.

WE HOPE YOU ENJOY USING YOUR NEW BLADE AQUA M-1 ROWING MACHINE. SHOULD YOU BE INTERESTED IN KEEPING UP WITH OUR EVER-GROWING FITNESS EQUIPMENT RANGE, TAKE A LOOK AT OUR WEBSITE [BLUEFINFITNESS.COM](https://www.bluefinfitness.com) AND FOLLOW US ON OUR SOCIALS:

**FACEBOOK** [FACEBOOK.COM/BLUEFINFITNESS](https://www.facebook.com/bluefinfitness)

**INSTAGRAM** [@BLUEFINFITNESS](https://www.instagram.com/bluefinfitness)

**TWITTER** [@BLUEFIN\\_FITNESS](https://twitter.com/bluefin_fitness)

**LINKEDIN** [LINKEDIN.COM/BLUEFIN-FITNESS](https://www.linkedin.com/company/bluefin-fitness)

THE BLUEFIN FITNESS TEAM

## SAFETY PRECAUTIONS

**i AS PREVIOUSLY MENTIONED, PLEASE ENSURE THAT ALL PERSONS USING THE BLADE AQUA HAVE READ AND UNDERSTOOD THIS MANUAL BEFORE USE.**

**WE RECOMMEND YOU KEEP THIS MANUAL FOR FUTURE REFERENCE.**

**The following general safety information must be observed when using the Blade Aqua M-1.**

- Always consult your physician before starting any exercise program, considering any medical or physical conditions that may put your health and safety at risk, especially if you are taking any medication for your heart, blood pressure or cholesterol levels.
- Stop exercising immediately if you experience any of the following whilst exercising: sharp pain, tightness in your chest, irregular heartbeat, shortness of breath, dizziness, or nausea. If you do experience any of the above, consult your physician before continuing any exercise.
- Always keep children and animals away from the rowing equipment. It is intended for adult use only.
- Place the equipment on a solid, flat level surface, ideally with a protective cover, to protect your flooring. Always ensure there is a minimum of two feet or 60cm of space around the equipment.
- Ensure that all nuts and bolts are securely fastened before using the equipment.
- Regularly examine the equipment for any damage and/or wear and tear to maintain the overall safety conditions.

- If you find any defective components while assembling the equipment, or you hear any unusual noises coming from the equipment during exercise, cease using the equipment immediately. Do not continue using the equipment until the problem has been rectified.
- Wear suitable workout clothing when using the equipment. Avoid wearing loose clothing that may get caught.
- Do not place fingers or small objects into the moving parts of the equipment. The maximum weight capacity of this unit is 150kg.
- Move the equipment with consideration and care for yourself and others around you. Seek assistance if necessary.
- Do not place the equipment within any extreme temperatures or conditions, including damp areas, which may lead to corrosion and operational issues.
- This equipment is designed for indoor and home use only. It is not intended for commercial use.

**⚠ WARNING: IF YOU ARE OVER THE AGE OF 45 OR HAVE PRE-EXISTING HEALTH CONDITIONS, PLEASE CONSULT YOUR PHYSICIAN BEFORE USING THE EQUIPMENT.**

**BLUEFIN FITNESS ASSUMES NO RESPONSIBILITY FOR PERSONAL INJURY OR PROPERTY DAMAGE SUSTAINED BY OR THROUGH THE USE OF THIS PRODUCT.**

## HARDWARE PARTS LIST

**i** BEFORE INSTALLING THE BLADE AQUA M-1, ENSURE THAT ALL OF THE FOLLOWING PARTS ARE INCLUDED:

NB. SOME SMALLER COMPONENTS MAY ALREADY BE PRE-FITTED TO LARGER COMPONENTS TO ASSIST WITH INSTALLATION.



19 x1



20 x1



80 M8 x1



59 M8\*15 x4



61 M4\*12 x2



62 M8\*15 x4



68 M8\*15 x8



72 M6\*10 x2



66 M8\*65 x4



74 OD20\*ID8.5\*1.5 x8

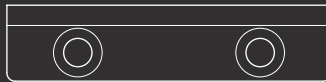

40 x1



93 S5 x1



94 S13-17 x1

## PRE-ASSEMBLY CHECKLIST

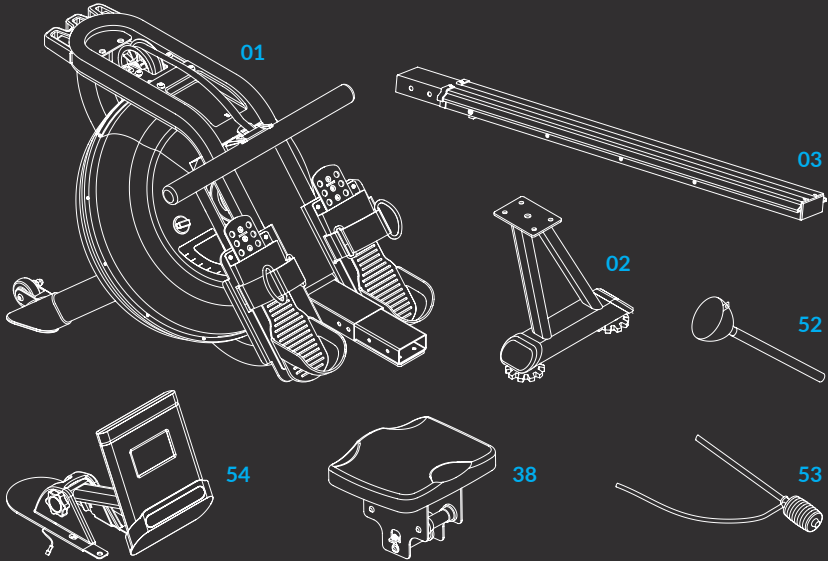

PART	DESCRIPTION	QUANTITY
01	Main Frame	x1
02	Rear Stabiliser	x1
03	Slide Rail	x1
38	Seat	x1
52	Funnel	x1
53	Pumping Siphon	x1
54	Computer	x1

# 01

## ASSEMBLY INSTRUCTIONS

**ⓘ NOTE: WE RECOMMEND HAVING TWO PEOPLE TO ASSEMBLE THE EQUIPMENT**

- Slide the **Seat 38** onto the **Slide Rail 03**.
- Secure the **Limit Pad 40** with **x2 Flat Cross Screws 72**.
- Attach the **Rear Stabiliser 02** to the **Slide Rail 03** with **x4 Washers 74** and **x4 Outer Hex Screws 59**.
- Tighten with **Spanner 94**.



**72 M6\*10 x2**



**59 M8\*15 x4**



**94 S13-17 x1**



**74 OD20\*ID8.5\*1.5 x4**

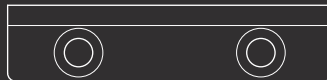

**40 x1**

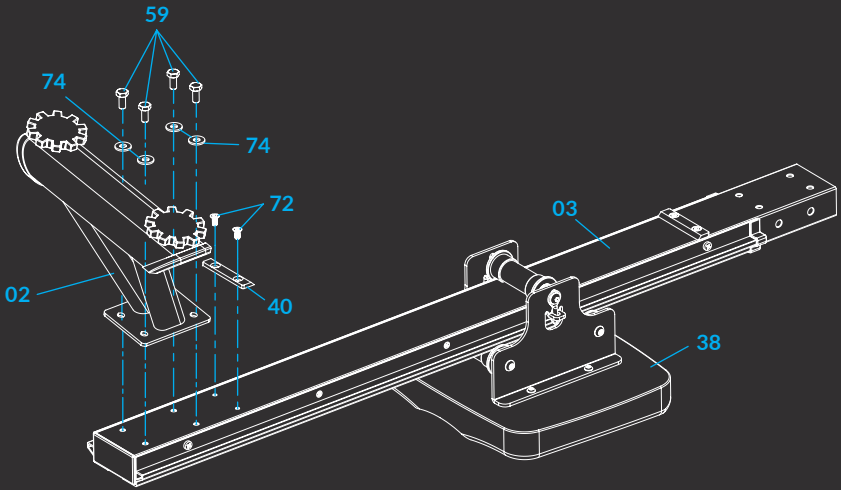

# 02

## ASSEMBLY INSTRUCTIONS

- Secure the Left/Right Decorative for Rail 19 and 20 with x2 Cross Screw 61 onto the Slide Rail 03. Tighten with Spanner 94.



19 x1



20 x1



61 M4\*12 x2



94 S13-17 x1

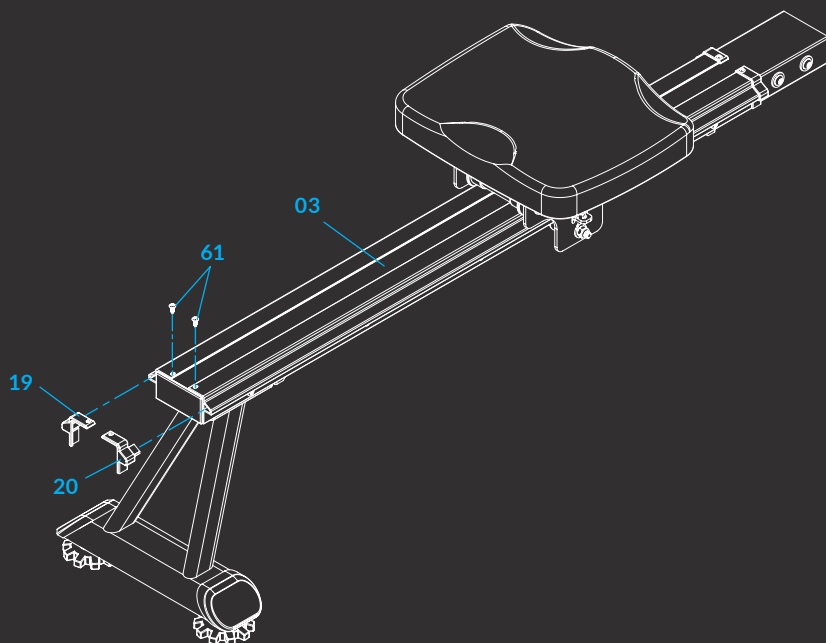

# 03

## ASSEMBLY INSTRUCTIONS

① MOVE THE SEAT 38 TO THE FRONT OF THE SLIDE RAIL 03 BEFORE ASSEMBLY TO PREVENT IT FROM MOVING DURING ASSEMBLY.

- Attach the Slide Rail 03 to the Main Frame 01 by using x4 Washers 74 x4 Screws 68 and x4 Flat Screws 62.
- Insert all 8 screws partially into the holes first, and then tighten with Allen Wrench 93.



62 M8\*15 **x4**



68 M8\*15 **x4**



74 OD20\*ID8.5\*1.5 **x4**



93 S5 **x1**

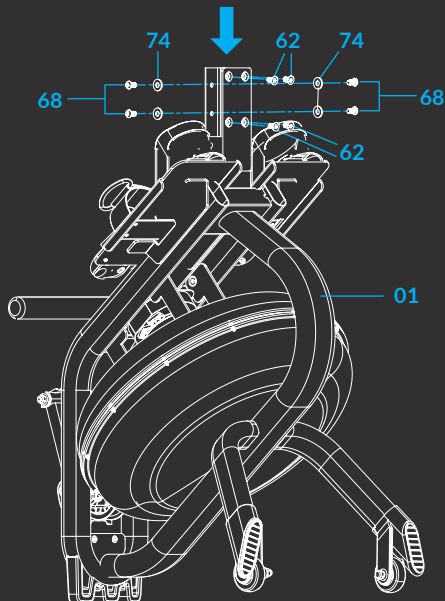
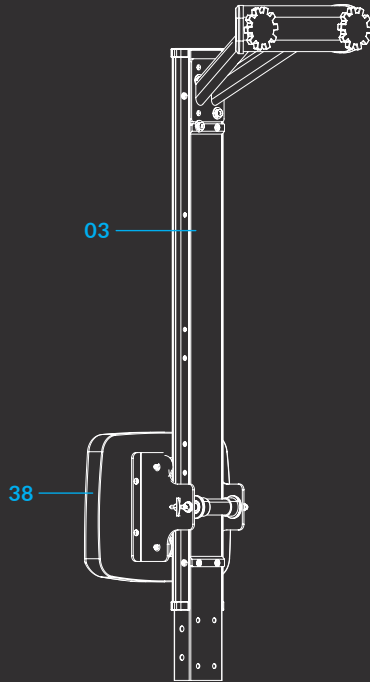

# 04

## ASSEMBLY INSTRUCTIONS

- Attach the support for Console 54 to Main Frame 1, ensuring the wires are connected. Then tighten with x4 Screws 68 and Allen Wrench 93.



66 M8\*65 x4



80 M8 x1

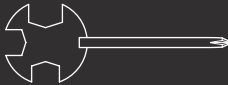

94 S13-17 x1



93 S5 x1



74 OD20\*ID8.5\*1.5 x2

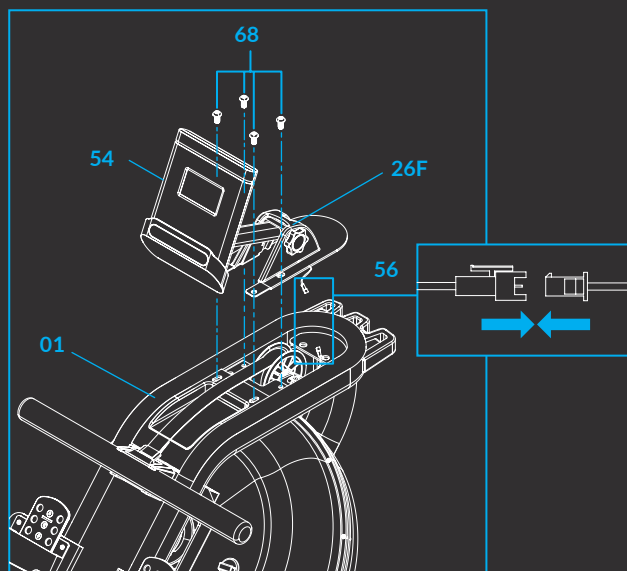

Unlock



Lock

To release turn anticlockwise 3 times,  
adjust the **Console 54** angle then turn  
clockwise to lock.

# 05

## WATER TANK

NEVER USE POOL CHLORINE OR CHLORINE BLEACH TO FILL THE WATER TANK AS THIS WILL DAMAGE THE TANK AND VOID THE WARRANTY.

ADD 1X WATER PURIFICATION TABLET EVERY 2-3 MONTHS, OR AS NEEDED. IF THE WATER TURNS CLOUDY, REPLACE THE WATER IN THE TANK.

DO NOT CONSUME THE WATER FROM THE TANK. ALWAYS REMOVE WATER FROM THE TANK BY USING THE SIPHON PUMP AND DISPOSE OF IT SAFELY.

### FILLING AND EMPTYING

- Remove **Fill Plug 50** from the **Upper Tank Cover 24**.
- To fill the tank with water, refer to **Fig. A**.  
Insert the **Funnel 52** into the tank, then use a cup or the **Siphon Pump 53** and a bucket to fill the tank. Use the water level gauge on the side of the tank to measure desired water level.
- To empty the tank, refer to **Fig. B**.  
Place a bucket next to the rower, and use the **Siphon Pump 53** to pump out the water from the tank into the bucket.
- Insert the **Fill Plug 50** into the **Upper Tank Cover 24**.  
Wipe excess water off the frame.

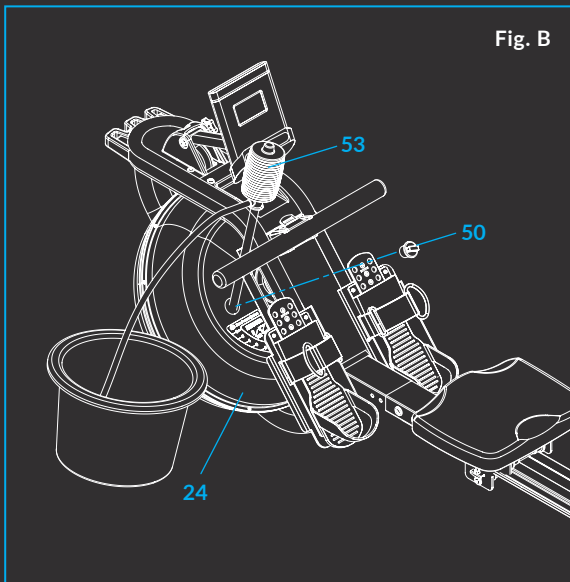
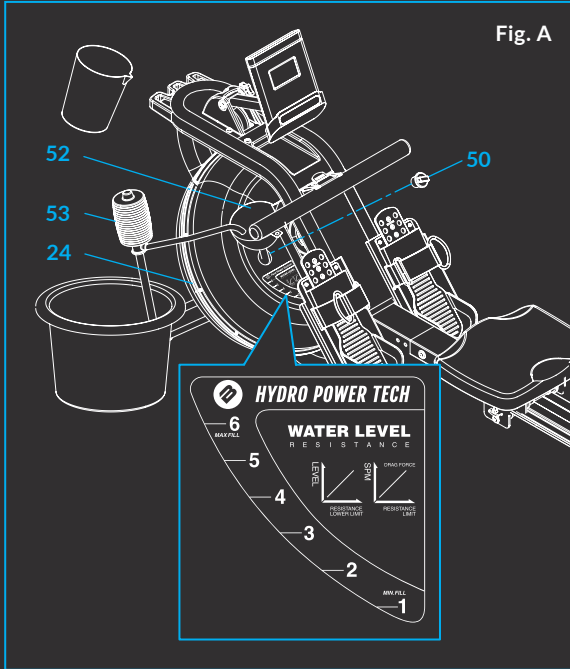

## WATER TANK

### CARE AND MAINTENANCE

- Water purification tablets help maintain the condition of the water for continued use.
- You should use distilled water to fill your tank.
- Once you insert the water purification tablet into the water tank, commence rowing to stir the tablet, ensuring that it is dissolved within the water.
- Each water purification tablet contains around 167mg of sodium dichloroisocyanurate. Please avoid any contact with metal objects to avoid any corrosion or rust occurring.

 **WATER PURIFICATION TABLETS AREN'T INCLUDED WITH THE PRODUCT DUE TO RESTRICTIONS ON INTERNATIONAL SHIPPING. PLEASE PURCHASE WATER PURIFICATION TABLETS SEPARATELY FROM A RELIABLE LOCAL VENDOR OR ONLINE RETAILER.**



# 06

## MOVING YOUR BLADE AQUA

- To move the rower, lift up the **Rear Stabilizer 02** until the **Moving Wheels 18** on the front stabiliser touches the ground.
- With the wheels on the ground, gently wheel and transport the rower to your desired location with ease.

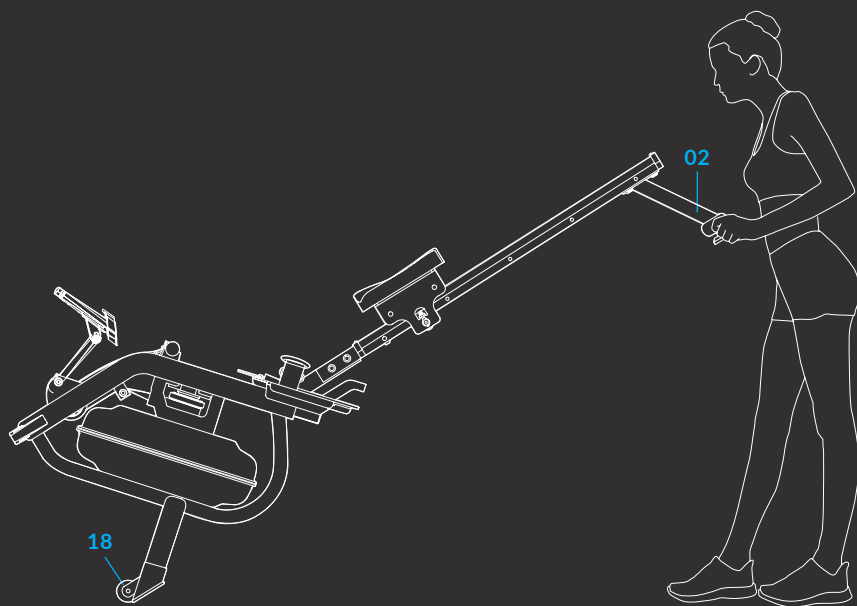

## STABILISING YOUR BLADE AQUA

 CAUTION! KEEP HANDS CLEAR OF THE SLIDING SIDE RAILS WHEN ADJUSTING YOUR BLADE AQUA AS THE MOVEMENT OF THE SEAT MAY CAUSE INJURY.

- Should the machine ever feel imbalanced during use, adjust the **Adjust Knob 23** below the **Rear Stabilizer 02** of the machine to stabilize the rower.

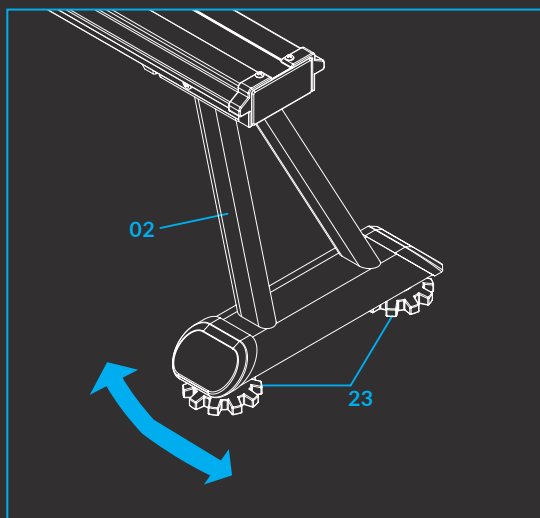

## STORING YOUR BLADE AQUA

 NB. ENSURE THAT YOU MOVE THE SEAT 38 TO THE FRONT OF THE SIDE RAIL 3 WHEN RAISING THE ROWER UPWARDS SO THAT THE SEAT DOESN'T MOVE DURING TRANSPORT.

 CAREFULLY FOLD THE SIDE RAIL UP, ENSURING THAT YOU AND ANYONE AROUND YOU WILL NOT BE AFFECTED.

- When not in use, save space by storing the rower away in a vertical position. To do so, lift the **Rear Stabilizer 02** and raise the rower upwards.
- If you're not planning on using the rower for over one month, empty the tank before storing away.

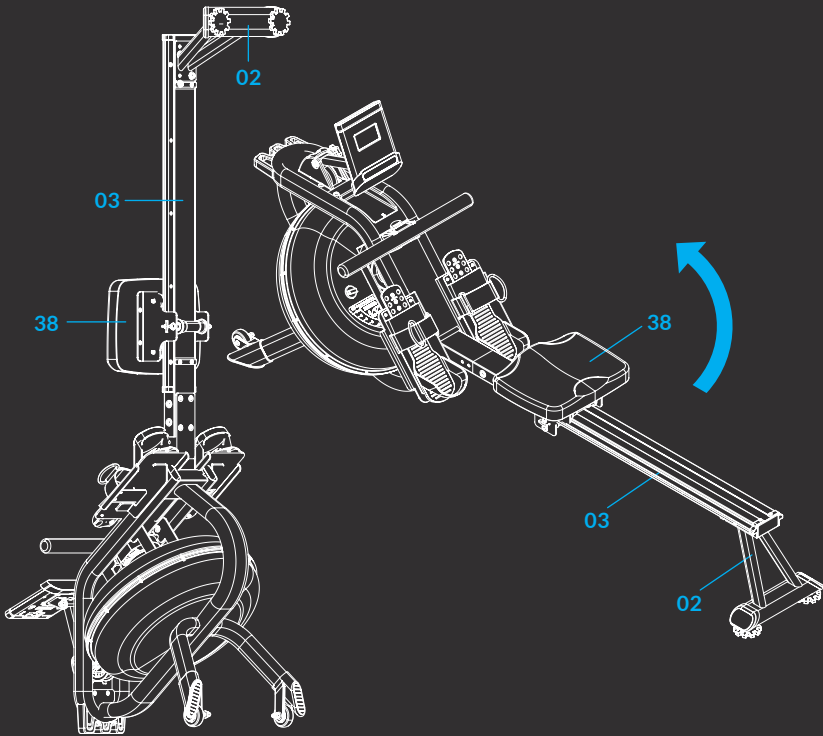



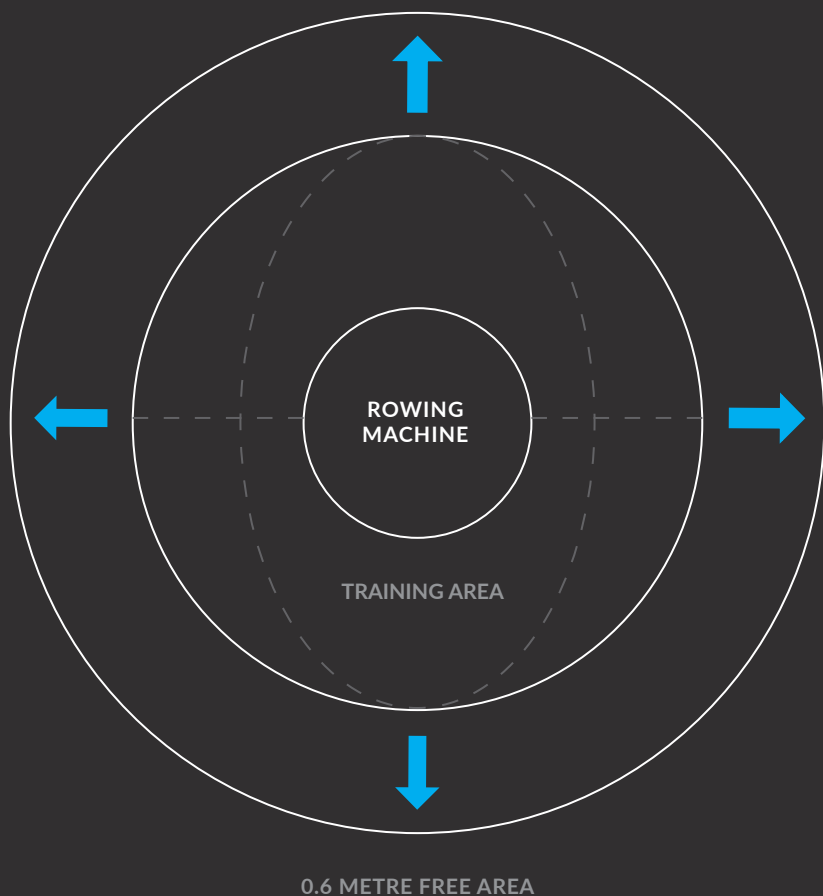

# CONSOLE FUNCTIONS

## FUNCTION BUTTONS

<b>MODE</b>	Push down to select functions. Push down to reset Time/Count/Distance and Calories for 2 seconds.
<b>SET</b>	To set the values of Time/Count/Distance/Calories and Pulse when not in scan mode.
<b>RESET</b>	Push down to reset Time/Count/Distance/Calories and Pulse.

## FUNCTIONS AND OPERATIONS

Press the **MODE** button, select **TIME**, at which point the word **SCAN** will appear on the left-hand side of the monitor. From here all 6 functions will appear on the display for 6 seconds each: **TIME**, **COUNT**, **DISTANCE**, **CALORIE**, **RPM** and **PULSE**.

When your desired function appears on the screen, press the **MODE** button to choose this function and select the parameters you want to measure during your workout.

<b>TIME</b>	Displays how long you have been exercising.
<b>COUNT</b>	Displays the amount of rowing strokes you are achieving.
<b>DISTANCE</b>	Displays the distance of exercise covered from start to end.
<b>CALORIES</b>	Displays the number of calories burned during the exercise.
<b>RPM</b>	Displays the number of rowing strokes you are achieving per minute.
<b>PULSE</b>	Displays your current heart rate during the exercise. <i>The wireless heartbeat chest belt can also be worn for a more accurate heart rate measurement.</i>

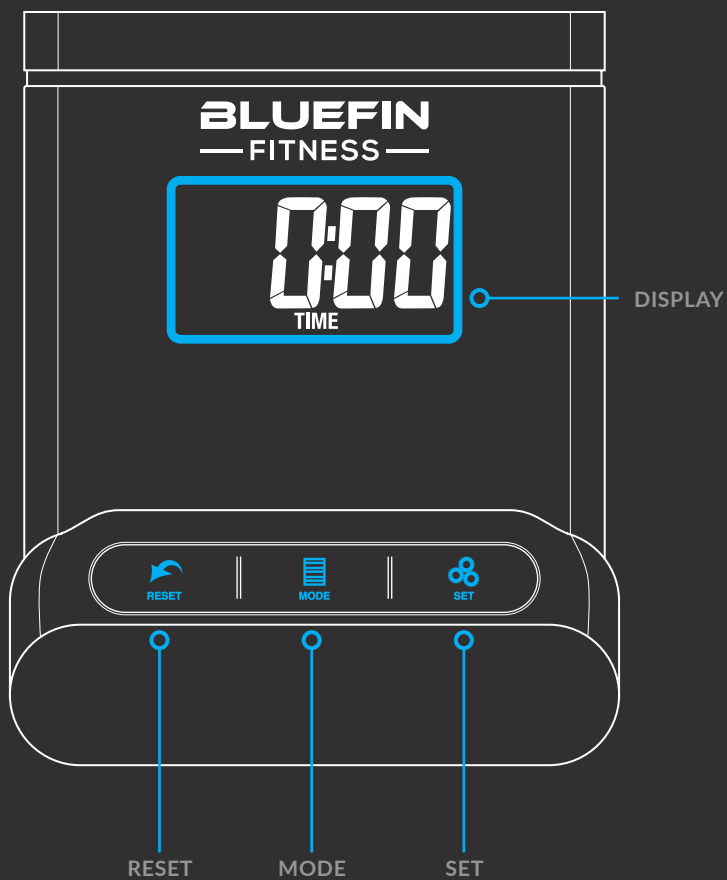

# CONSOLE OPERATION

## TARGET TRAINING SETTINGS

This console has five target training modes: Time, Count, Distance, Calories and Pulse. Once you have chosen your training mode, press the MODE button to remove the SCAN flashing on the display.

**TIME** Press the MODE button, choose TIME, and press the SET button to set how long you want to exercise for. You can press and hold the set button to speed up the setting. When you have reached your required time, release the button. Once you start working out on the rower the timer will start and count down from the time duration set. Once the training goal has been completed the console will beep, signalling the end of your training. If you continue to train from this point the display will automatically begin to count up from zero.

**COUNT** Press the MODE button, choose COUNT, and press the SET button to set the number of full rowing strokes you want to achieve. You can press and hold the set button to speed up the setting. When you have reached your required count, release the button. Once you start working out on the rower the display will begin counting down from the target set. Once the training goal has been completed the console will beep, signalling the end of your training. If you continue to train from this point the display will automatically begin to count up from zero.

**DISTANCE** Press the MODE button, choose DISTANCE, and press the SET button to set the virtual distance you want to achieve. You can press and hold the set button to speed up the setting. When you have reached your required distance, release the button. Once you start working out on the rower the display will begin counting down from the target set. Once the training goal has been completed the console will beep, signalling the end of your training. If you continue to train from this point the display will automatically begin to count up from zero.

**CALORIES** Press the MODE button, choose CALORIES, and press the SET button to the number of calories you want to burn during your workout. You can press and hold the set button to speed up the setting. When you have reached your required calorie number, release the button. Once you start working out on the rower the display will begin counting down from

the target set. Once the training goal has been completed the console will beep, signalling the end of your training. If you continue to train from this point the display will automatically begin to count up from zero.

**PULSE** Press the MODE button, choose PULSE, and press the SET button to set the target heart rate you want to achieve during your workout. You can press and hold the set button to speed up the setting. When you have reached your required heart rate number, release the button. Once you start working out on the rower the display will begin counting down from the target set. Once the training goal has been completed the console will beep, signalling the end of your training. If you continue to train from this point the display will automatically begin to count up from zero.

You can always change the training targets set by pressing the RESET button to clear all current settings. You can then choose your training targets again with the above instructions.

**NB. IF THE DISPLAY IS FAINT OR SHOWS NO FIGURES, PLEASE REPLACE THE DISPLAY BATTERIES.**

**THE CONSOLE WILL AUTOMATICALLY TURN OFF IF THERE IS NO SIGNAL RECEIVED AFTER 4 MINUTES.**

**THE MONITOR WILL AUTOMATICALLY TURN ON WHEN YOU BEGIN USING THE ROWER.**

**THE MONITOR WILL AUTOMATICALLY START TO CALCULATE YOUR TRAINING AS SOON AS YOU START ROWING, AND UP TO 4 SECONDS AFTER YOU FINISH.**

FUNCTION	SCAN	Every 6 seconds
	TIME	0:00~99:59
	COUNT	0~9999 TIMES
	DISTANCE	0~9999 METRES
	CALORIES	0.0~999.9 CAL
	RPM	0~999 TIMES/MIN
	PULSE	40~220 BPM
BATTERY TYPE		2pcs of SIZE -AA orUM -3
OPERATING TEMPERATURE		0°C~ +40°C
STORAGE TEMPERATURE		-10°C~ +60°C

## KINOMAP FITNESS APP

### ADDING THE APP

- Search for KINOMAP on your smartphone's app store and download.
- After the download is complete, open the KINOMAP app and register your personal details.
- Turn Bluetooth on and ensure that the Blade Aqua console is powered on and in the wake-up state.
- Sync your Blade Aqua to the KINOMAP app as follows:



## 01

Press MORE to bring up the Equipment page, select **Equipment Management**.

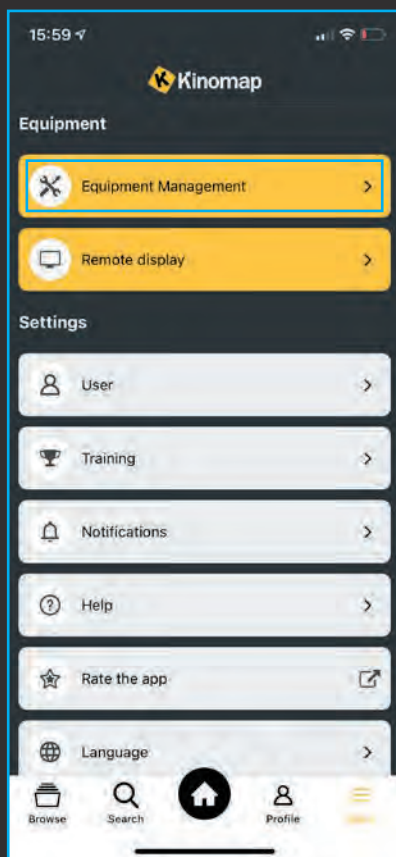

## 02

Press the + icon.

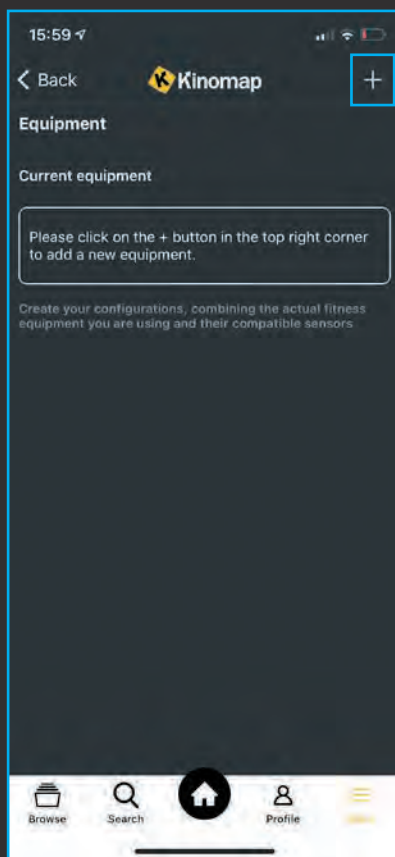

# 03

Select the **Rowing** icon.



# 04

Select the **Bluefin Fitness** icon.

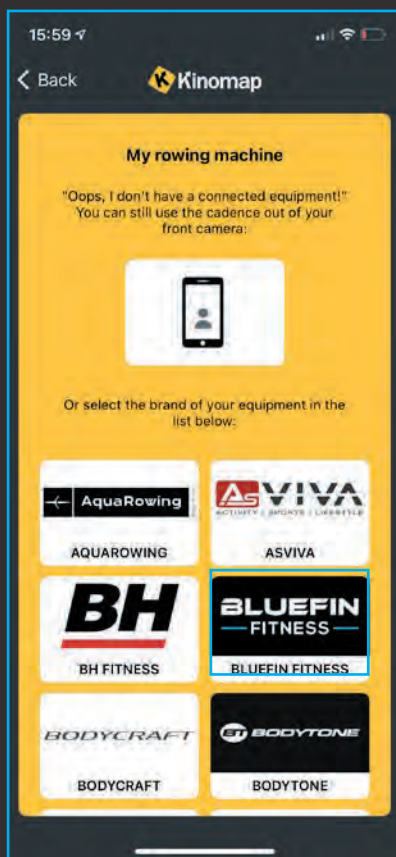

## 05

Select **Blade Aqua M-1**.

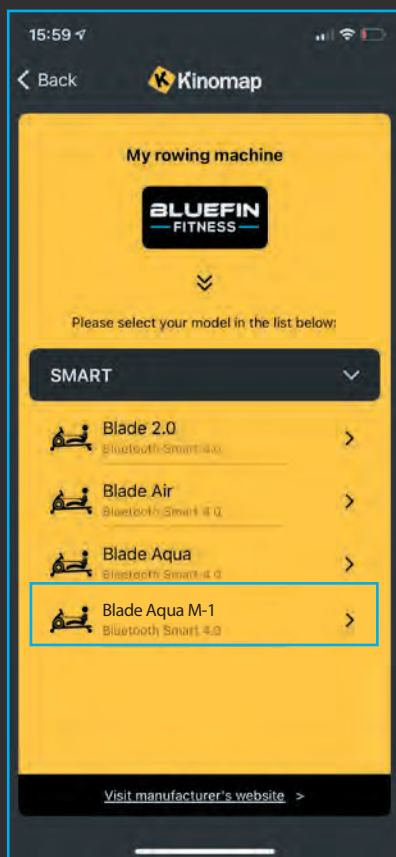

## 06

Add your **Blade Aqua M-1** to complete, start your exercise.

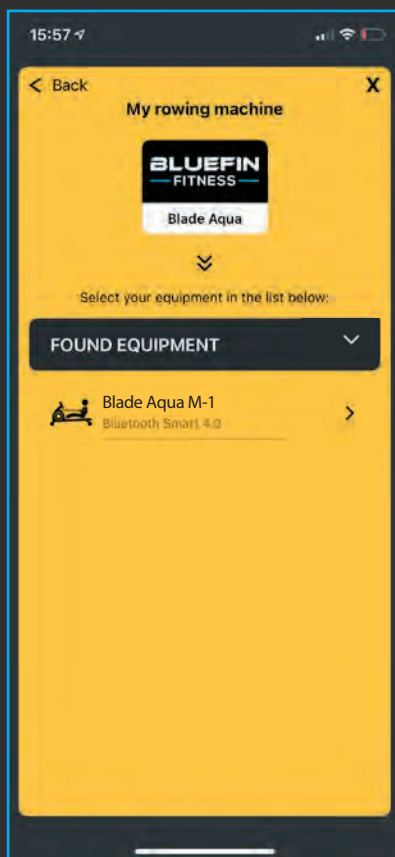

## WARM UP AND COOL DOWN

TO PREVENT INJURIES, YOU SHOULD ALWAYS WARM-UP AND COOL-DOWN WITH VARIOUS STRETCHES BEFORE AND AFTER EACH WORKOUT.

WE RECOMMEND THE FOLLOWING STRETCHES, WHICH WILL REDUCE THE RISK OF ANY MUSCLE INJURY OR SPASM DURING EXERCISE. NEVER OVERSTRETCH OR PULL YOUR MUSCLES.

### SIDE BENDS

Pass one arm up and over your head, bending your upper body in the same direction. Hold this position for 10 to 15 seconds and slowly straighten yourself back up. Repeat this 3 times for each side.

### TOE TOUCH

Slowly bend forward from your waist, letting your back and shoulders relax as you stretch towards your toes. Reach down as far as you can go and hold for 15 seconds. Then relax and repeat 3 times.

### CALF-ACHILLES STRETCH

Lean against a wall with your left leg in front of the right and your arms on the wall. Keep your right leg straight and your left foot on the floor, bend the left leg and lean forward by moving your hips toward the wall. Hold, then repeat on the other leg for 15 seconds. Repeat 3 times for each leg.

### QUADRICEPS STRETCH

With one hand against a wall for balance, reach behind you and pull your right foot up. Bring your heel as close to your buttocks. Hold for 10-15 seconds. Repeat three times for each foot.

### INNER THIGH STRETCH

Sit with the soles of your feet together and your knees pointing outwards. Pull your feet as close to your groin as possible. Gently push your knees towards the floor. Hold for 15 seconds. Then relax and repeat 3 times.

# ROWING EXERCISES

## USING YOUR ROWING MACHINE REGULARLY WILL:

- Improve your overall physical fitness, strengthening the heart and improving circulation as well as exercising all the major muscle groups: the back, waist, arms, shoulders, hips and legs.
- Tone your muscles & in conjunction with a calorie-controlled diet: it will help you lose weight. Rowing is an extremely effective form of exercise.

## THE BASIC ROWING STROKE

- Sit on the saddle and fasten your feet to the pedals using the straps. Then take hold of the rowing bar.
- Take up the starting position, leaning forward with your arms straight and knees bent as shown in **Fig 1**.
- Push yourself backwards, straightening your back and legs at the same time **Fig 2**.
- Continue this movement until you are leaning slightly backwards, during this stage you should bring your arms out of the side **Fig 3**. Then return to stage 2 and repeat.

## TRAINING

- Rowing is a strenuous form of exercise, so it's best to start training with low resistance and for short periods if you are a beginner. As you progress, you can increase the resistance and training time to suit your needs and fitness goals.

We recommend you begin training on alternate days, approx. 3 times a week to give your body time to recover between workouts.

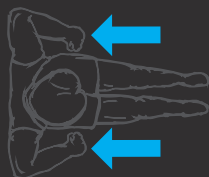

Fig 1



Fig 2



Fig 3

# ROWING EXERCISES

## ALTERNATE ROWING STYLES

### ARMS ONLY ROWING

This rowing style will tone the muscles in your arms, shoulders, back and stomach. Sit as shown in **Fig 4** with your legs straight, lean forward and grasp the handles. In a gradual and controlled manner lean back to just past the upright position continuing to pull the handles towards your chest. Return to the starting position and repeat.

### LEGS ONLY ROWING

This exercise will tone the muscles in your legs and back. With your back straight and arms stretched out, bend your legs until you are grasping the rowing arm handles in the starting position, **Fig 7**. Use your legs to push your body back whilst keeping your arms and back straight.

### MUSCLE TONING

The most effective way to tone your muscles while rowing is to set a high resistance while being mindful not to cause any injury by over-exerting your muscles. We recommend always warming up and cooling down at a light resistance and choosing to increase your resistance in the final part of your training when your muscles have warmed up properly.

### WEIGHT LOSS

The more effort you put into your rowing workouts, the more calories you will burn. Look to gradually increase the resistance, duration and effort you put into each workout, as these factors will assist you in losing weight.



Fig 4



Fig 5



Fig 6



Fig 7



Fig 8



Fig 9

## MANUFACTURER WARRANTY

📌 THE BLUEFIN WARRANTY COVERS ANY TECHNICAL FAULTS WITH YOUR ITEM. IF YOU NEED TO MAKE A WARRANTY CLAIM CONTACT US VIA EMAIL AT: [SUPPORT@BLUEFINTRADING.CO.UK](mailto:SUPPORT@BLUEFINTRADING.CO.UK)

### YOUR WARRANTY DOES NOT COVER THE FOLLOWING:

- General wear and marks from use.
- Water damage.
- Damage due to improper use.
- Chassis damage & scratching due to improper use or dropping.
- Electronic damage due to improper use or dropping.
- Your warranty begins on receipt of delivery.
- Technical faults are covered for 12 months.

If you have any questions regarding your warranty please email us at: [support@bluefintrading.co.uk](mailto:support@bluefintrading.co.uk)



William Vaughan, CEO  
Bluefin Trading Ltd.

## EU DECLARATION OF CONFORMITY

For the latest & up-to-date EU declaration of conformity for this product, please visit: [www.bluefinfitness.com/manuals/bladeaqua\\_m1\\_DoC.pdf](http://www.bluefinfitness.com/manuals/bladeaqua_m1_DoC.pdf)

Importer Address:  
Bluefin Trading Ltd  
Keelham Farm  
Hebden Bridge  
UK  
HX7 8TG  
[www.bluefinfitness.com](http://www.bluefinfitness.com)



### WASTE ELECTRICAL AND ELECTRONIC EQUIPMENT

Do not dispose of this device with domestic waste. The components of the device must be separately recycled or disposed of according to local regulations. The system operator may also return any waste electrical and electronic equipment to the manufacturer at the end of their lifetime. Charges incurred for transport to the manufacturer will be at the expense of the owner of the waste electrical and electronic equipment.



### BATTERY DIRECTIVE

Do not dispose of any batteries with domestic waste. Please recycle or safely dispose of batteries in accordance with local regulations. Any batteries supplied by the manufacturer or distributor can be returned at the end of their lifetime for recycling and safe disposal. Charges incurred for transport to the manufacturer or distributor will be at the expense of the owner of the batteries.



### RECYCLING OF PACKAGING MATERIALS

Do not dispose of packaging with domestic waste. All packaging materials can be safely recycled according to local regulations.

# BLADE AQUA

M-1 WATER RESISTANCE ROWER

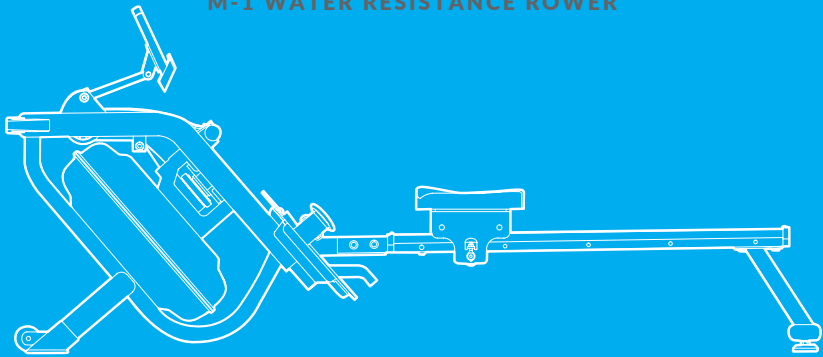



## WILLKOMMEN BEI DER BLUEFIN FITNESS COMMUNITY!

LIEBE KUNDIN, LIEBER KUNDE,

VIELEN DANK, DASS DU DICH FÜR DAS BLUEFIN FITNESS BLADE AQUA M-1 RUDERGERÄT ENTSCIEDEN HABEN. UM SICHERZUSTELLEN, DASS DU DAS MAXIMUM AUS DEINEM NEUEN RUDERGERÄT HERAUSHOLST, SOLLTEST DU DARAUF ACHTEN, DASS ALLE PERSONEN, DIE DAS GERÄT BENUTZEN, DIE FOLGENDE ANLEITUNG VOR DEM GEBRAUCH SORGFÄLTIG LESEN UND VERSTEHEN.

BLUEFIN FITNESS ÜBERNIMMT KEINE HAFTUNG FÜR SCHÄDEN, DIE DURCH UNSACHGEMÄSSEN GEBRAUCH ODER FALSCHER BEDIENUNG ENTSTEHEN.

WIR WÜNSCHEN DIR VIEL SPASS MIT DEINEM NEUEN BLADE AQUA M-1 RUDERGERÄT. SOLLTEST DU DARAN INTERESSIERT SEIN, ÜBER UNSER STÄNDIG WACHSENDES ANGEBOT AN FITNESSGERÄTEN AUF DEM LAUFENDEN ZU BLEIBEN, DANN SCHAU DOCH EINFACH AUF UNSERER WEBSITE VORBEI: [BLUEFINFITNESS.COM](https://www.bluefinfitness.com) UND FOLGE UNS AUF UNSEREN SOCIAL-MEDIA-KANÄLEN:

**FACEBOOK** [FACEBOOK.COM/BLUEFINFITNESS](https://www.facebook.com/bluefinfitness)

**INSTAGRAM** [@BLUEFINFITNESS](https://www.instagram.com/bluefinfitness)

**TWITTER** [@BLUEFIN\\_FITNESS](https://twitter.com/bluefin_fitness)

**LINKEDIN** [LINKEDIN.COM/BLUEFIN-FITNESS](https://www.linkedin.com/company/bluefin-fitness)

DEIN BLUEFIN FITNESS TEAM

## SICHERHEITSHINWEISE

**i** WIE BEREITS ERWÄHNT SOLLTEST DICH VERGEWISSERN, DASS ALLE PERSONEN, DIE DAS BLADE AQUA BENUTZEN, DIESES HANDBUCH VOR DER BENUTZUNG GELESEN UND VERSTANDEN HABEN.

WIR EMPFEHLEN DIR, DIESE ANLEITUNG AUFZUBEWAHREN.

Die folgenden allgemeinen Sicherheitshinweise müssen bei der Benutzung des Blade Aqua beachtet werden.

- Konsultiere immer deinen Arzt, bevor du mit einem Trainingsprogramm beginnst. Berücksichtige dabei alle medizinischen oder körperlichen Bedingungen, die deine Gesundheit und Sicherheit gefährden könnten, insbesondere wenn du Medikamente für dein Herz, deinen Blutdruck oder deinen Cholesterinspiegel einnimmst.
- Höre sofort auf zu trainieren, wenn du während des Trainings eines der folgenden Symptome verspürst: Stechende Schmerzen, Engegefühl in der Brust, unregelmäßiger Herzschlag, Kurzatmigkeit, Schwindel oder Übelkeit. Wenn du eines der oben genannten Symptome verspürst, halte Rücksprache mit deinem Arzt, bevor du weiter trainierst.
- Halte immer Kinder und Tiere von dem Rudergerät fern. Das Gerät ist nur für den Gebrauch durch Erwachsene vorgesehen.
- Stelle das Gerät auf eine feste, flache, ebene Oberfläche, idealerweise auf eine Bodenabdeckung, um deinen Boden zu schützen. Achte darauf, dass immer mindestens 60 cm Platz um das Gerät herum ist.
- Vergewissere dich, dass alle Schrauben und Muttern fest angezogen sind, bevor du das Gerät benutzt.
- Untersuche das Gerät regelmäßig auf Beschädigungen und/oder Verschleiß.
- Wenn du bei der Montage des Geräts defekte Komponenten findest oder während des Trainings ungewöhnliche Geräusche hörst, dann stelle den Gebrauch des Geräts sofort ein. Benutze das Gerät nicht weiter, bis das Problem behoben wurde.

- Trage geeignete Trainingskleidung, wenn du das Gerät benutzt. Vermeide es, lose Kleidung zu tragen, die sich verhaken könnte.
- Stecke keine Finger oder kleine Gegenstände in die beweglichen Teile des Geräts.
- Die maximale Gewichtskapazität dieses Geräts beträgt 150 kg.
- Transportiere das Gerät vorsichtig und hole dir bei Bedarf Hilfe.
- Stelle das Gerät nicht unter extremen Temperaturen oder Bedingungen auf, auch nicht in feuchten Bereichen, da dies zu Korrosion und Betriebsproblemen führen kann.
- Dieses Gerät ist nur für den Gebrauch in Innenräumen und zu Hause gedacht. Es ist nicht für den kommerziellen Gebrauch bestimmt.

**⚠ WARNUNG: WENN DU ÜBER 45 JAHRE ALT BIST ODER GESUNDHEITLICHE VORERKRANKUNGEN HAST, DANN KONSULTIERE BITTE DEINEN ARZT, BEVOR DU DAS GERÄT BENUTZT.**

**BLUEFIN FITNESS ÜBERNIMMT KEINE VERANTWORTUNG FÜR PERSONEN- ODER SACHSCHÄDEN, DIE DURCH DIE VERWENDUNG DIESES PRODUKTS ENTSTEHEN.**

## STÜCKLISTE DER EISENWAREN

**i** VERGEWISSERE DICH VOR DER INSTALLATION DES BLADE AQUA M-1, DASS ALLE FOLGENDEN TEILE VORHANDEN SIND:

HINWEIS. EINIGE KLEINERE KOMPONENTEN KÖNNEN BEREITS AN GRÖßEREN KOMPONENTEN VORMONTIERT SEIN, UM DIE MONTAGE ZU ERLEICHTERN.



19 x1

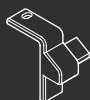

20 x1



80 M8 x1



59 M8\*15 x4



61 M4\*12 x2



62 M8\*15 x4



68 M8\*15 x8



72 M6\*10 x2



66 M8\*65 x4



74 OD20\*ID8.5\*1.5 x8



40 x1



93 S5 x1



94 S13-17 x1

## CHECKLISTE VORMONTAGE

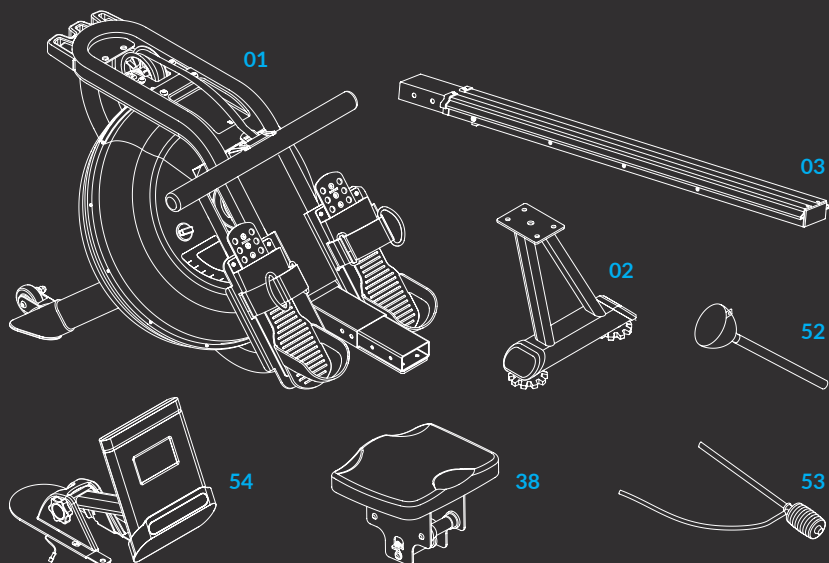

TEIL	BESCHREIBUNG	ANZAHL
01	Hauptrahmen	x1
02	Hinterer Stützfuß	x1
03	Gleitschiene	x1
38	Sitz	x1
52	Trichter	x1
53	Pumpensiphon	x1
54	Computer	x1

# 01

## MONTAGEANWEISUNG

**i HINWEIS: WIR EMPFEHLEN ZWEI PERSONEN FÜR DIE MONTAGE.**

- Schiebe den **Sitz 38** auf die **Gleitschiene 03**.
- Befestige das **Endpolster 40** mit **x2 Flachkreuzschrauben 72**.
- Befestige den hinteren **Stützfuß 02** an der **Gleitschiene 03** mit **x4 Unterlegscheiben 74** und **x4 Außensechskantschrauben 59**.
- Mit dem **Schraubenschlüssel 94** fest ziehen.



**72** M6\*10 **x2**



**59** M8\*15 **x4**



**94** S13-17 **x1**



**74** OD20\*ID8.5\*1.5 **x4**

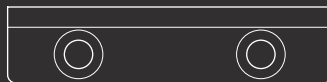

**40** **x1**

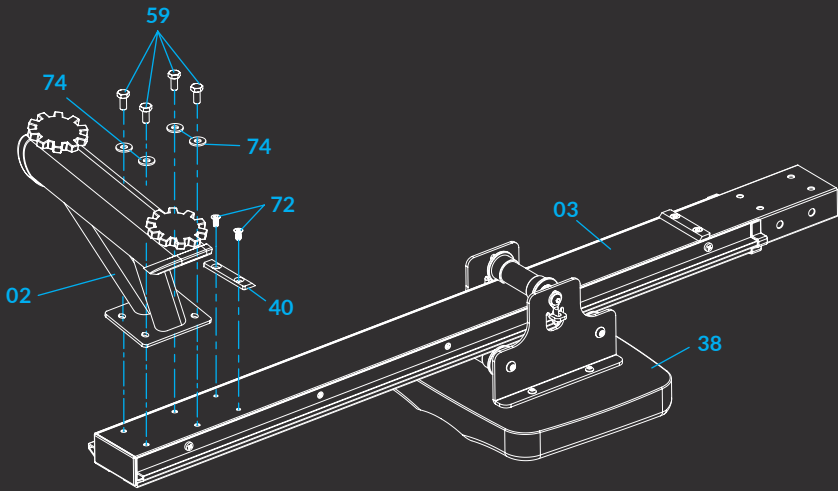

# 02

## MONTAGEANWEISUNG

- Befestige das linke/rechte Dekoteil für Schienen 19 und 20 mit x2 Kreuzschrauben 61 auf der Gleitschiene 03. Mit Schraubenschlüssel 94 festziehen.



19 x1



20 x1



61 M4\*12 x2



94 S13-17 x1

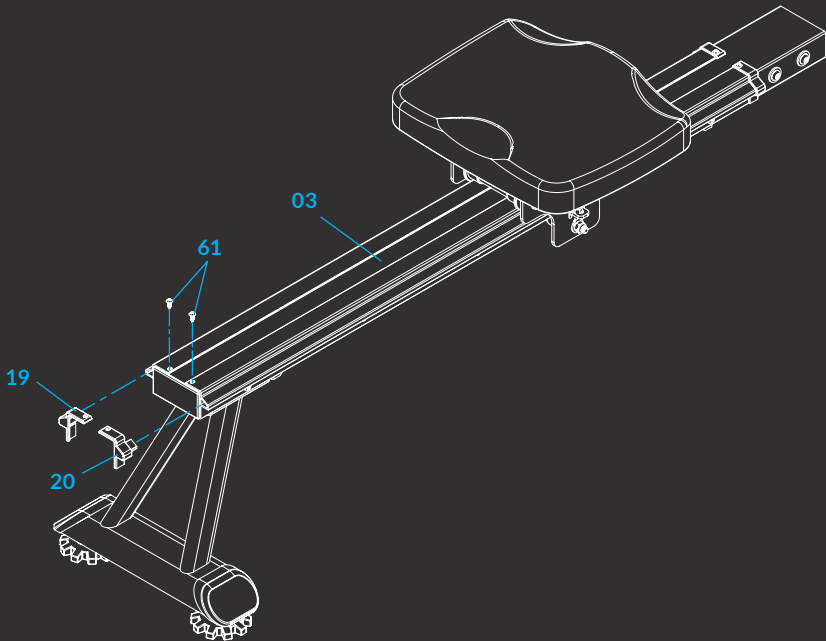

# 03

## MONTAGEANWEISUNG

① SCHIEBE DEN SITZ 38 VOR DER MONTAGE AN DIE VORDERSEITE DER GLEITSCHIENE 03, UM ZU VERHINDERN, DASS ER SICH WÄHREND DER MONTAGE BEWEGT..

- Befestige die Gleitschiene 03 am Hauptrahmen 01 mit Hilfe von x4 Unterlegscheiben 74, x4 Schrauben 68 und x4 Flachschraben 62.
- Setze alle 8 Schrauben zuerst teilweise in die Löcher ein und ziehe sie dann mit dem Inbusschlüssel 93 fest.



62 M8\*15 x4



68 M8\*15 x4



74 OD20\*ID8.5\*1.5 x4



93 S5 x1

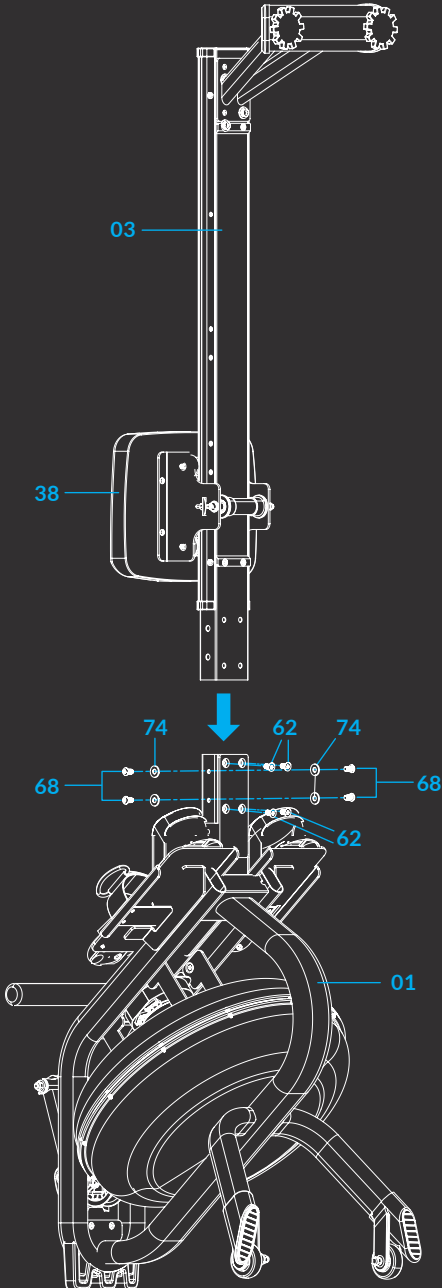

# 04

## MONTAGEANWEISUNG

- Befestige die Stütze für **Konsole 54** am **Hauptrahmen 01** und stelle sicher, dass die Drähte verbunden sind. Mit **x4 Schrauben 68** und **Inbusschlüssel 93** festziehen.



**66** M8\*65 **x4**



**80** M8 **x1**



**94** S13-17 **x1**



**93** S5 **x1**



**74** OD20\*ID8.5\*1.5 **x2**

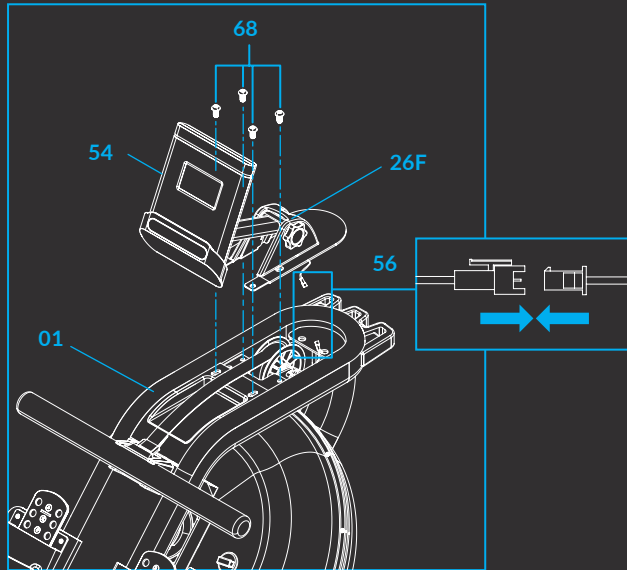

Entriegeln



Verriegeln

Zum Entriegeln 3 Positionen gegen den Uhrzeigersinn drehen, den Winkel der **Konsole 54** einstellen und dann zum Verriegeln im Uhrzeigersinn drehen.

# 05

## WASSERTANK

VERWENDE NIEMALS POOLCHLOR ODER CHLORBLEICHE ZUM BEFÜLLEN DES WASSERTANKS, DA DIES DEN TANK BESCHÄDIGT UND DIE GARANTIE VERFÄLLT.

FÜGE ALLE 2-3 MONATE ODER NACH BEDARF 1X WASSERREINIGUNGSTABLETTEN HINZU. WENN DAS WASSER TRÜB WIRD, ERSETZE DAS WASSER IM TANK.

VERBRAUCHE NICHT DAS WASSER AUS DEM TANK. ENTFERNE DAS WASSER IMMER MIT HILFE DER SIPHONPUMPE AUS DEM TANK UND ENTSORGE ES AUF SICHERE WEISE.

### BEFÜLLEN UND ENTLEREEN

- Entferne den **Einfüllstopfen 50** aus dem oberen **Tankdeckel 24**.
- Um den Tank mit Wasser zu füllen, siehe **Abb. A**.  
Führe den **Trichter 52** in den Tank ein und benutze dann einen Becher oder die **Siphonpumpe 53** und einen Eimer, um den Tank mit Wasser zu füllen. Benutze den Wasserstandsanzeiger an der Seite des Tanks, um den gewünschten Wasserstand zu messen.
- Um den Tank zu entleeren, siehe **Abb. B**.
- Stelle einen Eimer neben das Rudergerät und benutze die **Siphonpumpe 53**, um das Wasser aus dem Tank in den Eimer zu pumpen.
- Stecke den **Füllstopfen 50** in den oberen **Tankdeckel 24**.  
Wische das überschüssige Wasser vom Rahmen ab.

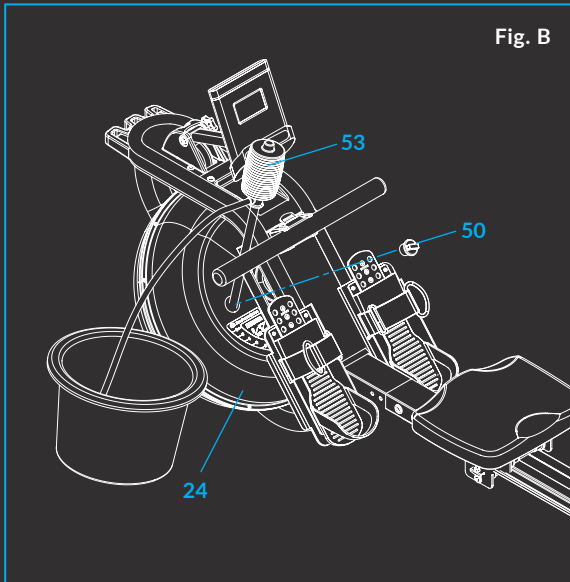
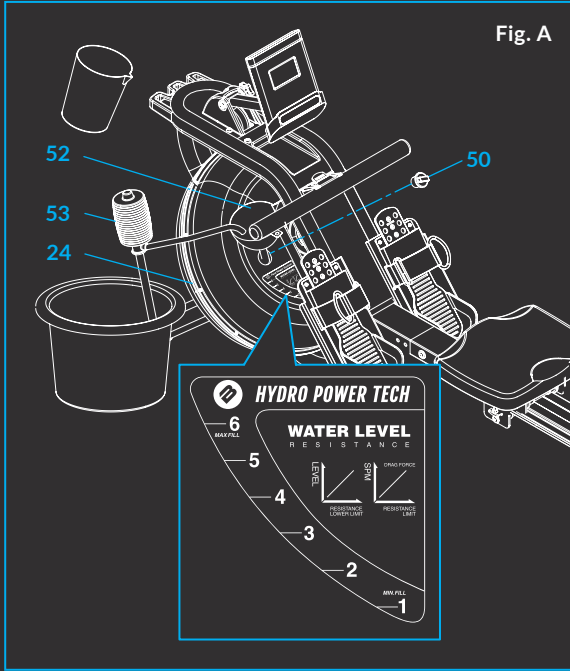

## WASSERTANK

### PFLEGE UND WARTUNG

- Die Wasserreinigungstabletten helfen dabei, den ordnungsgemäßen Zustand des Wassers für den weiteren Gebrauch zu erhalten.
- Du solltest destilliertes Wasser verwenden, um deinen Tank zu füllen.
- Sobald du die Wasserreinigungstablette in den Wassertank eingelegt hast, beginne zu rudern, um die Tablette umzurühren und sicherzustellen, dass sie im Wasser aufgelöst wird.
- Jede Wasserreinigungstablette enthält etwa 167mg Natriumdichlorisocyanurat. Bitte vermeide jeglichen Kontakt mit metallischen Gegenständen, damit keine Korrosion oder Rost entsteht.

 **DIE WASSERREINIGUNGSTABLETTEN SIND AUFGRUND VON BESCHRÄNKUNGEN FÜR DEN INTERNATIONALEN VERSAND NICHT IM LIEFERUMFANG DES PRODUKTS ENTHALTEN. BITTE KAUF DIE WASSERREINIGUNGSTABLETTEN SEPARAT ENTWEDER BEI EINEM ZUVERLÄSSIGEN LOKALEN ANBIETER ODER EINEM ONLINE-HÄNDLER.**



## TRANSPORT DEINES BLADE AQUA

- Um das Rudergerät zu bewegen, hebe die hintere **Stütze 02** an, bis die **Transporträder 18** am vorderen Stützfuß den Boden berühren.
- Wenn sich die Räder auf dem Boden befinden, kannst du das Rudergerät leicht rollen und an den gewünschten Ort transportieren.

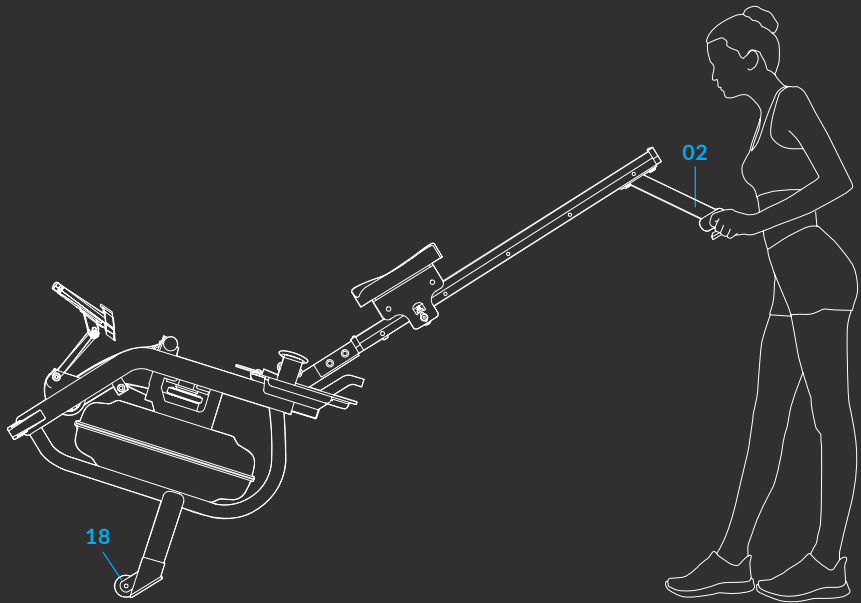

## STABILISIERUNG DEINES BLADE AQUA

 **VORSICHT! HALTE DIE HÄNDE VON DEN GLEITENDEN SEITENSCHIENEN FERN, WENN DU DEIN BLADE AQUA EINSTELLST, DA DIE BEWEGUNG DES SITZES ZU VERLETZUNGEN FÜHREN KANN.**

- Sollte sich das Gerät während des Gebrauchs jemals unausgeglichen anfühlen, verstelle den **Einstellknopf 23** unterhalb des hinteren **Stützfußes 02**, um das Rudergerät zu stabilisieren.

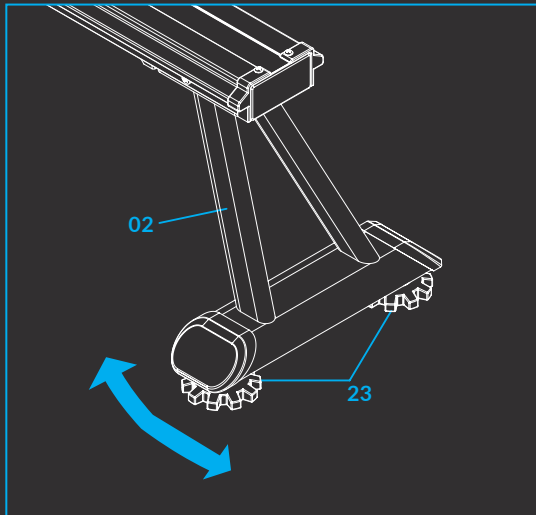

## AUFBEWAHRUNG DEINER KLINGE AQUA

 HINWEIS. ACHE DARAUF, DASS DU DEN SITZ 38 BEIM HOCHKLAPPEN DES RUDERGERÄTES NACH VORNE AN DEN SEITENHOLM 3 SCHIEBST, DAMIT SICH DER SITZ BEIM TRANSPORT NICHT VERSCHIEBT.

 KLAPPE DEN SEITENHOLM VORSICHTIG NACH OBEN UND STELLE SICHER, DASS DU UND ANDERE PERSONEN IN DEINER UMGEBUNG NICHT GEFÄHRDET WERDEN.

- Wenn du das Gerät nicht benutzt, kannst du es platzsparend in einer senkrechten Position verstauen. Dazu hebst du den hinteren **Stützfuß 02** an und hebst das Rudergerät nach oben.
- Wenn du das Rudergerät länger als einen Monat nicht benutzen willst, entleere den Tank, bevor du es lagerst.

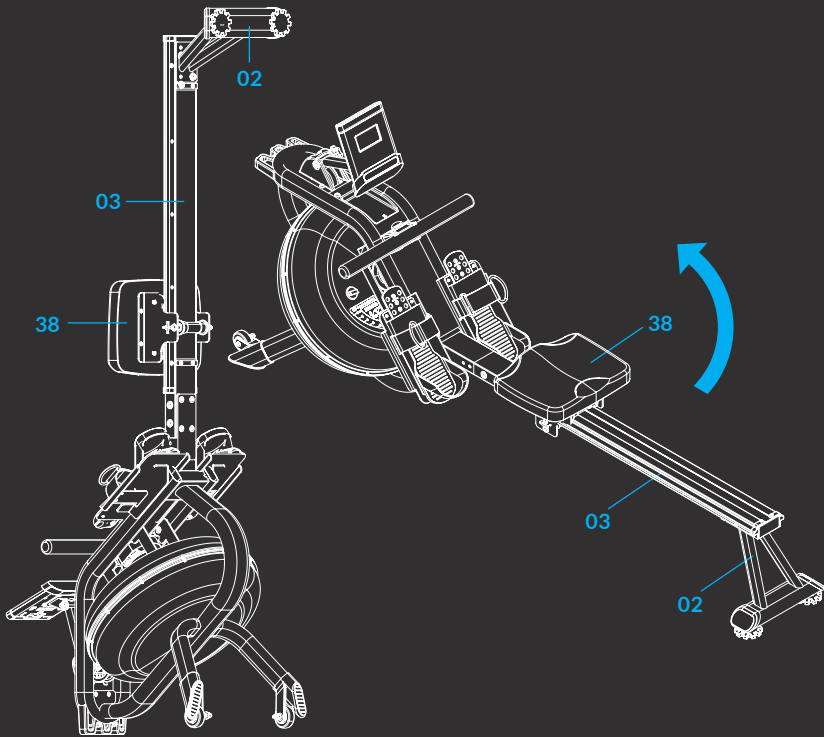



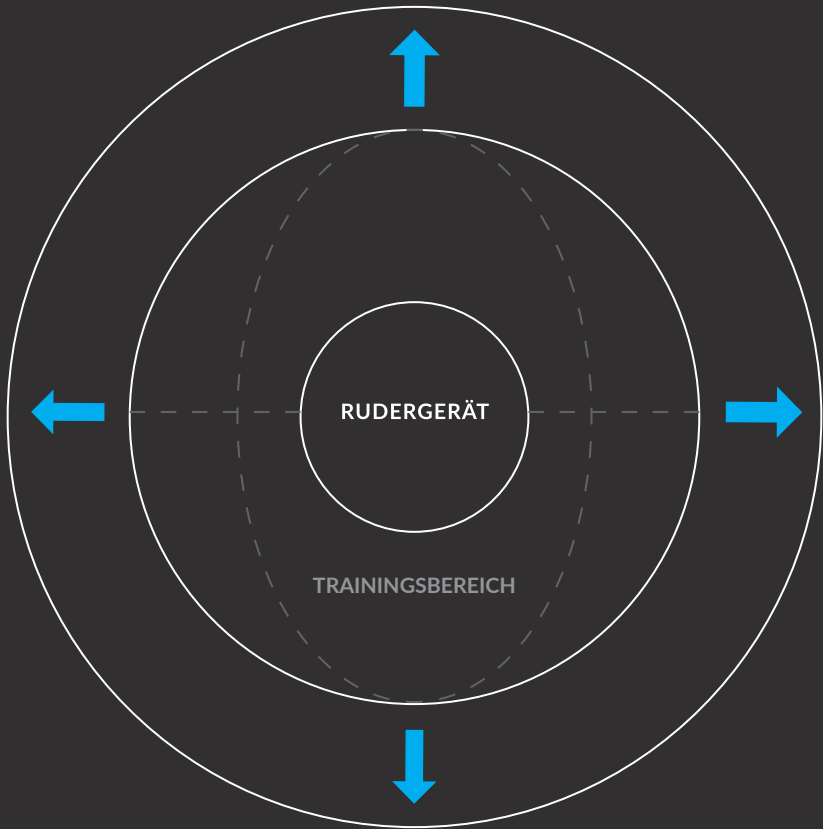

0,6 METER FREIE FLÄCHE

# KONSOLENFUNKTIONEN

## FUNKTIONSTASTEN

<b>MODE</b>	Nach unten drücken, um Funktionen auszuwählen. Für 2 Sekunden nach unten drücken, um Zeit/Zähler/Distanz und Kalorien zurückzusetzen.
<b>SET</b>	Zum Einstellen der Werte von Zeit/Zähler/Distanz/Kalorien und Puls wenn nicht im Scan-Modus.
<b>RESET</b>	Nach unten drücken, um Zeit/Zahl/Distanz/Kalorien und Puls zurückzusetzen.

## FUNKTIONEN UND BEDIENUNGEN

Drücke die MODE-Taste und wähle TIME, woraufhin das Wort "SCAN" auf der linken Seite des Monitors erscheint. Von hier aus werden alle 6 Funktionen für jeweils 6 Sekunden auf dem Display angezeigt: TIME, COUNT, DISTANCE, CALORIE, RPM und PULSE.

Wenn deine gewünschte Funktion auf dem Bildschirm erscheint, drücke die MODE-Taste, um diese Funktion auszuwählen und wähle die Parameter, die du während deines Trainings messen möchtest.

<b>TIME (ZEIT)</b>	Zeigt an, wie lange du bereits trainiert hast.
<b>COUNT</b>	Zeigt die Anzahl der Ruderschläge an, die du schaffst.
<b>DISTANCE (Distanz)</b>	Zeigt die zurückgelegte Distanz der Übung vom Start bis zum Ende an.
<b>CALORIES (Kalorien)</b>	Zeigt die Anzahl der Kalorien an, die während der Übung verbrannt wurden.
<b>RPM</b>	Zeigt die Anzahl der Ruderschläge an, die du pro Minute erreichst.
<b>PULSE</b>	Zeigt deine aktuelle Herzfrequenz während des Trainings an. <i>Der kabellose Herzschlag-Brustgurt kann auch für eine genauere Herzfrequenzmessung getragen werden.</i>

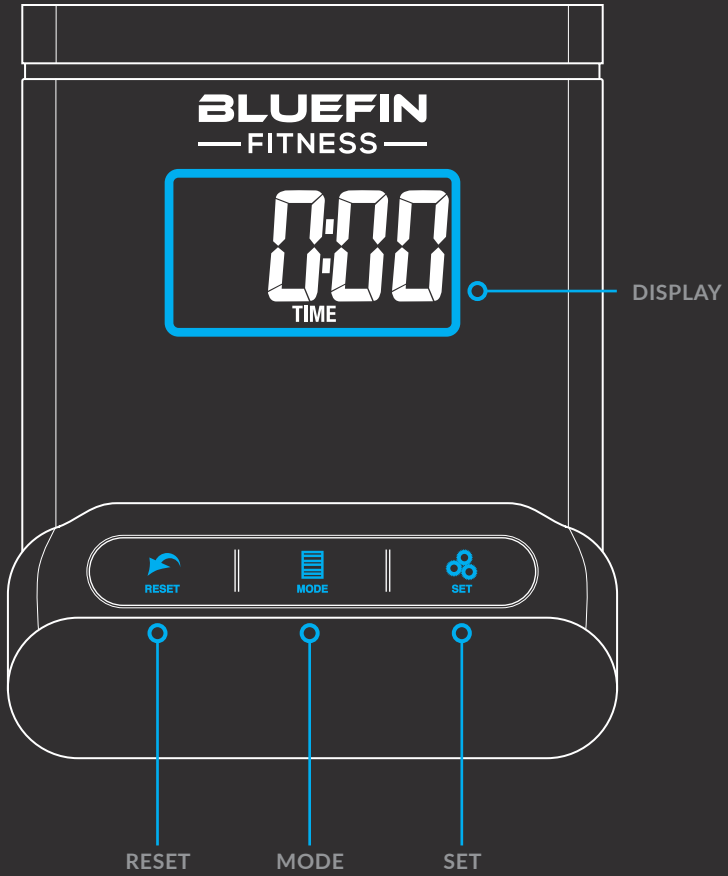

# KONSOLENBETRIEB

## ZIELTRAININGSMODI

Diese Konsole verfügt über fünf Zieltrainingsmodi: Zeit, Zählen, Distanz, Kalorien und Puls. Sobald du deinen Trainingsmodus gewählt hast, drücke die MODE-Taste, damit SCAN nicht mehr auf dem Display blinkt.

**ZEIT** Drücke die MODE-Taste, wähle TIME und drücke die SET-Taste, um einzustellen, wie lange du trainieren möchtest. Du kannst die SET-Taste drücken und halten, um den Einstellungsprozess zu beschleunigen. Wenn du deine gewünschte Zeit erreicht hast, lasse die Taste los. Sobald du mit dem Training auf dem Rudergerät beginnst, startet der Timer und zählt ab der eingestellten Zeitdauer herunter. Sobald das Trainingsziel erreicht ist, piept die Konsole und signalisiert damit das Ende deines Trainings. Wenn du ab diesem Punkt weiter trainierst, beginnt die Anzeige automatisch von Null hochzuzählen.

**ZÄHLEN** Drücke die MODE-Taste, wähle COUNT und drücke die SET-Taste, um die Anzahl der vollen Ruderschläge einzustellen, die du erreichen willst. Du kannst die Set-Taste drücken und halten, um den Einstellungsprozess zu beschleunigen. Wenn du deine gewünschte Anzahl erreicht hast, lasse die Taste los. Sobald du anfängst, auf dem Rudergerät zu trainieren, beginnt die Anzeige vom eingestellten Ziel herunterzuzählen. Sobald das Trainingsziel erreicht ist, piept die Konsole und signalisiert das Ende deines Trainings. Wenn du ab diesem Punkt weiter trainierst, beginnt die Anzeige automatisch von Null hochzuzählen.

**DISTANCE** Drücke die MODE-Taste, wähle DISTANCE und drücke die SET-Taste, um die virtuelle Distanz einzustellen, die du erreichen möchtest. Du kannst die Set-Taste gedrückt halten, um den Einstellungsprozess zu beschleunigen. Wenn du deine gewünschte Distanz erreicht hast, lasse die Taste los. Sobald du anfängst auf dem Rudergerät zu trainieren, beginnt das Display vom eingestellten Ziel herunterzuzählen. Sobald das Trainingsziel erreicht ist, piept die Konsole und signalisiert das Ende deines Trainings. Wenn du ab diesem Punkt weiter trainierst, beginnt die Anzeige automatisch von Null hochzuzählen.

**KALORIEN** Drücke die MODE-Taste, wähle KALORIEN und drücke die SET-Taste bis zu der Anzahl der Kalorien, die du während deines Trainings

verbrennen möchtest. Du kannst die SET-Taste drücken und halten, um den Einstellungsprozess zu beschleunigen. Wenn du deine gewünschte Kalorienzahl erreicht hast, lasse die Taste los. Sobald du anfängst auf dem Rudergerät zu trainieren, beginnt die Anzeige vom eingestellten Ziel herunterzuzählen. Sobald das Trainingsziel erreicht ist, piept die Konsole und signalisiert damit das Ende deines Trainings. Wenn du ab diesem Punkt weiter trainierst, beginnt die Anzeige automatisch von Null hochzuzählen.

**PULSE** Drücke die MODE-Taste, wähle PULSE und drücke die SET-Taste, um die Zielherzfrequenz einzustellen, die du während deines Trainings erreichen möchtest. Du kannst die Set-Taste drücken und halten, um den Einstellungsprozess zu beschleunigen. Wenn du deine gewünschte Herzfrequenzzahl erreicht hast, lasse die Taste los. Sobald du mit dem Training auf dem Rudergerät beginnst, beginnt die Anzeige vom eingestellten Ziel herunterzuzählen. Sobald das Trainingsziel erreicht ist, piept die Konsole und signalisiert das Ende deines Trainings. Wenn du ab diesem Punkt weiter trainierst, beginnt die Anzeige automatisch von Null hochzuzählen.

Du kannst die eingestellten Trainingsziele jederzeit ändern, indem du die RESET-Taste drückst, um alle aktuellen Einstellungen zu löschen. Du kannst dann deine Trainingsziele erneut mit den oben genannten Anweisungen auswählen..

**NB. IF THE DISPLAY IS FAINT OR SHOWS NO FIGURES,  
PLEASE REPLACE THE DISPLAY BATTERIES.**

**THE CONSOLE WILL AUTOMATICALLY TURN OFF IF THERE  
IS NO SIGNAL RECEIVED AFTER 4 MINUTES.**

**THE MONITOR WILL AUTOMATICALLY TURN ON WHEN  
YOU BEGIN USING THE ROWER.**

**THE MONITOR WILL AUTOMATICALLY START TO CALCULATE  
YOUR TRAINING AS SOON AS YOU START ROWING, AND UP TO  
4 SECONDS AFTER YOU FINISH.**

## KONSOLENBETRIEB

HINWEIS. WENN DAS DISPLAY SCHWACH IST ODER KEINE ZAHLEN ANZEIGT, TAUSCHE BITTE DIE BATTERIEN DES DISPLAYS AUS.

DIE KONSOLE SCHALTET SICH AUTOMATISCH AUS, WENN NACH 4 MINUTEN KEIN SIGNAL EMPFANGEN WIRD.

DER MONITOR SCHALTET SICH AUTOMATISCH EIN, WENN DU BEGINNST, DAS RUDERGERÄT ZU BENUTZEN.

DER MONITOR BEGINNT AUTOMATISCH MIT DER BERECHNUNG DEINES TRAININGS, SOBALD DU MIT DEM RUDERN BEGINNST, UND BIS ZU 4 SEKUNDEN NACH DEM ENDE.

FUNKTION:	SCAN	Alle 6 Sekunden
	ZEIT	0:00-99:59
	ZÄHLUNG	0-9999 MAL
	DISTANZ	0-9999 METER
	KALORIEN	0.0 - 999.9 CAL
	RPM	0-999 MAL-MIN
	PULS	40-220 BPM
BATTERIETYP	2 STÜCK SIZE -AA ODER UM-3	
BETRIEBSTEMPERATUR	0°C- +40°C	
LAGERTEMPERATUR	-10°C- +60°C	



## KINOMAP FITNESS-APP

### HINZUFÜGEN DER APP

- Suche im App-Store deines Smartphones nach KINOMAP und lade sie herunter.
- Nachdem der Download abgeschlossen ist, öffne die KINOMAP-App und registriere deine persönlichen Daten.
- Schalte Bluetooth ein und vergewissere dich, dass die Konsole des Blade Aqua eingeschaltet ist und sich im Aufwachzustand befindet.
- Synchronisiere dein Blade Aqua mit der KINOMAP App wie folgt:



## 01

Drücke auf More, um die Seite Ausrüstung aufzurufen, wähle Ausrüstungsverwaltung. (Equipment Management).

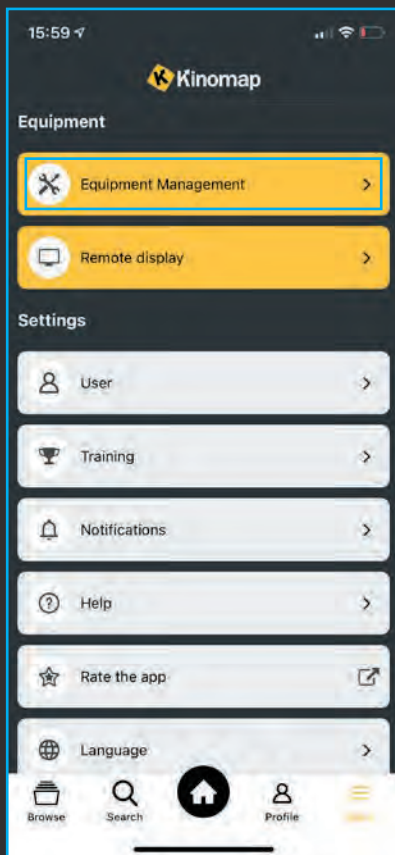

## 02

Drücke das + Symbol.

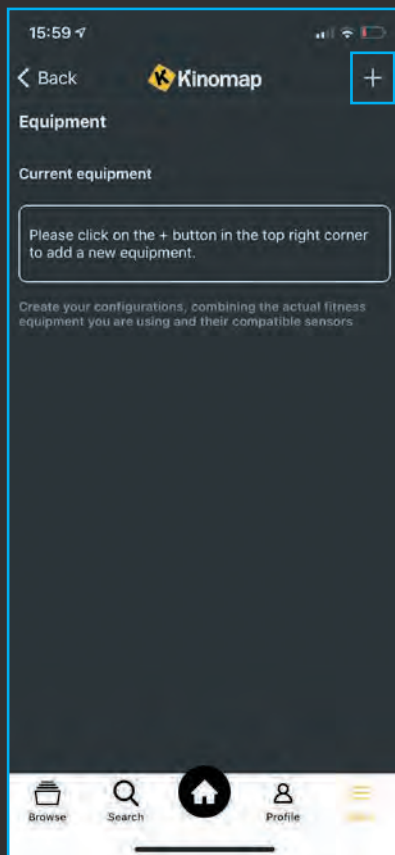

# 03

Wähle das Ruder-Symbol aus.



# 04

Wähle das Bluefin Fitness-Symbol aus.

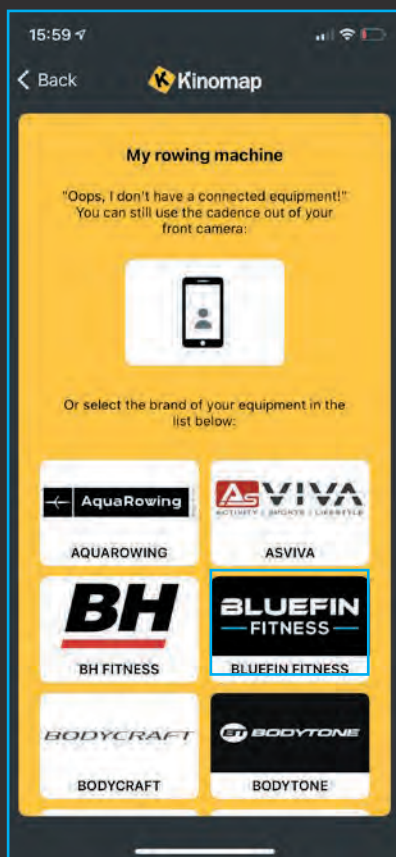

## 05

Wähle das **Blade Aqua M-1** aus.

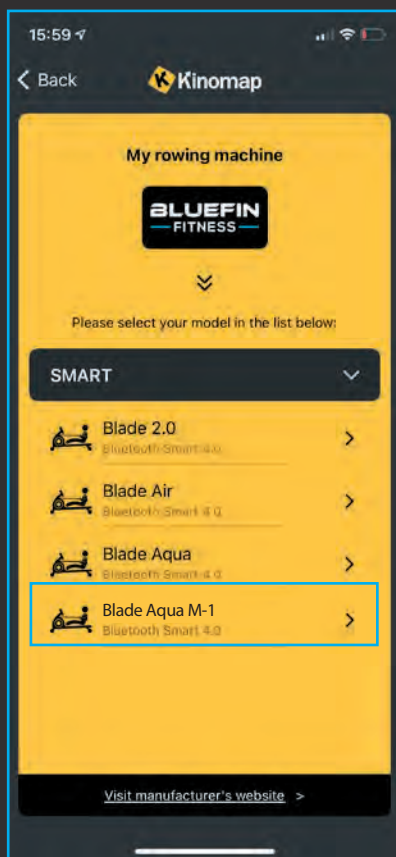

## 06

Füge dein **Blade Aqua M-1** hinzu und beginne mit deinem Training.

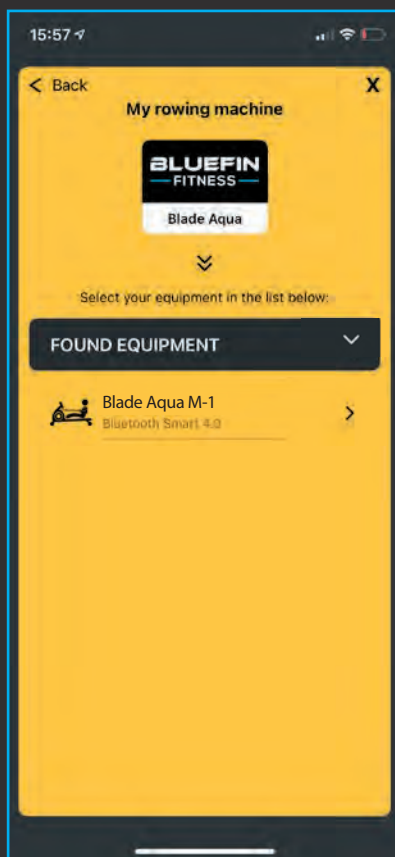

## AUFWÄRMEN UND COOL DOWN

UM VERLETZUNGEN VORZUBEUGEN, SOLLTEST DU DICH VOR UND NACH JEDEM TRAINING MIT VERSCHIEDENEN DEHNUNGEN AUFWÄRMEN UND ABKÜHLEN.

WIR EMPFEHLEN DIE FOLGENDEN DEHNUNGÜBUNGEN, DIE DAS RISIKO EINER MUSKELVERLETZUNG ODER EINES KRAMPFES WÄHREND DES TRAININGS REDUZIEREN. ÜBERDEHNE ODER ÜBERBEANSPRUCHE NIEMALS DEINE MUSKELN.

### SIDE BENDS

Führe einen Arm nach oben und über deinen Kopf und beuge deinen Oberkörper in die gleiche Richtung. Halte diese Position für 10 bis 15 Sekunden und richte dich langsam wieder auf. Wiederhole dies 3 Mal für jede Seite.

### BERÜHRUNG DER ZEHEN

Beuge dich langsam von der Taille aus nach vorne und entspanne deinen Rücken und deine Schultern, während du dich zu deinen Zehen streckst. Greife so weit wie möglich nach unten und halte die Position für 15 Sekunden. Wiederhole die Übung 3 Mal.

## DEHNUNG DER WADEN UND DER ACHILLES-SEHNE

Lehne dich mit dem linken Bein vor dem rechten an eine Wand und stütze dich mit den Armen an der Wand ab. Halte dein rechtes Bein gerade und deinen linken Fuß auf dem Boden, beuge das linke Bein und lehne dich nach vorne, indem du deine Hüfte zur Wand bewegst. Halte die Position und wiederhole sie dann mit dem anderen Bein für 15 Sekunden. Wiederhole die Übung 3 Mal für jedes Bein.

## DEHNUNG DES QUADRIZEPS

Stütze dich mit einer Hand an der Wand ab, greife hinter dich und ziehe deinen rechten Fuß hoch. Bringe deine Ferse so nah wie möglich an dein Gesäß. Für 10-15 Sekunden halten. Wiederhole diese Übung dreimal für jedes Bein.

## DEHNUNG DER INNEREN OBERSCHENKEL

Setze dich auf den Boden, die Fußsohlen sind zusammen und die Knie zeigen nach außen. Ziehe deine Füße so nah wie möglich an deine Leiste heran. Drücke deine Knie sanft in Richtung Boden. Halte die Position für 15 Sekunden. 3 Mal wiederholen.

# RUDERÜBUNGEN

WENN DU DEIN RUDERGERÄT REGELMÄSSIG BENUTZT,  
DANN WIRST DU FOLGENDE VORTEILE BEMERKEN:

- Verbesserung deiner allgemeinen körperlichen Fitness, Stärkung des Herzens und Verbesserung der Durchblutung sowie das Training aller wichtigen Muskelgruppen: Rücken, Taille, Arme, Schultern, Hüften und Beine.
- Straffung deiner Muskeln in Kombination mit einer kalorienkontrollierten Ernährung: Auf diese Weise kannst du an Gewicht verlieren, denn Rudern ist eine äußerst effektive Form des Trainings.

## DER NORMALE RUDERSCHLAG

- Setze dich auf den Sitz und platziere deine Füße mit Hilfe der Riemen an den Pedalen. Nimm dann die Ruderstange in die Hand.
- Nimm die Ausgangsposition ein, indem du dich nach vorne lehnst, die Arme sind dabei gestreckt und die Knie gebeugt (siehe Abb. 1).
- Drücke dich nach hinten und strecke gleichzeitig deinen Rücken und deine Beine durch (siehe Abb. 2).
- Setze diese Bewegung fort, bis du dich leicht nach hinten lehnst. Während dieser Phase solltest du deine Arme seitlich ausstrecken (siehe Abb. 3). Kehre dann zu Stufe 2 zurück und wiederhole die Übung.

## TRAINING

- Rudern ist eine anstrengende Form des Trainings. Daher ist es am besten, wenn du als Anfänger mit geringem Widerstand und nur für kurze Zeit trainierst. Wenn du Fortschritte machst, kannst du den Widerstand und die Trainingszeit erhöhen, um deinen Bedürfnissen und Fitnesszielen gerecht zu werden. Wir empfehlen dir, mit dem Training an abwechselnden Tagen ca. 3 Mal pro Woche zu beginnen, um deinem Körper Zeit zu geben, sich zwischen den Trainingseinheiten zu regenerieren.



Abb. 1



Abb. 2

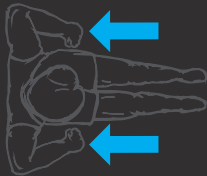

Abb. 3

# RUDERÜBUNGEN

## ABWECHSELNDE RUDERSTILE

### RUDERN NUR MIT DEN ARMEN

Dieser Ruderstil trainiert die Muskeln in deinen Armen, Schultern, Rücken und Bauch. Setze dich wie in **Abb. 4** gezeigt mit gestreckten Beinen auf das Gerät, lehne dich nach vorne und umfasse die Griffe. Lehne dich langsam und kontrolliert bis kurz hinter eine aufrechte Position zurück und ziehe die Griffe weiter in Richtung deiner Brust. Kehre in die Ausgangsposition zurück und wiederhole die Übung.

### RUDERN NUR MIT DEN BEINEN

Diese Übung trainiert die Muskeln in deinen Beinen und deinem Rücken. Beuge deine Beine mit geradem Rücken und gestreckten Armen und umfasse die Griffe in der Ausgangsposition (**Abb. 7**). Drücke nun deinen Körper mit Hilfe deiner Beine nach hinten, während du dabei deine Arme und deinen Rücken gerade hältst.

## MUSKELSTÄRKUNG

Der effektivste Weg, deine Muskeln beim Rudern zu trainieren, besteht darin, einen hohen Widerstand einzustellen und darauf zu achten, dass du deine Muskeln nicht überanstrengst. Wir empfehlen, dass du dich immer mit einem leichten Widerstand aufwärmst und abkühlst und den Widerstand im letzten Teil deines Trainings erhöhst, wenn sich deine Muskeln richtig aufgewärmt haben.

## GEWICHTSVERLUST

Je mehr Aufwand du in dein Rudertraining steckst, desto mehr Kalorien wirst du verbrennen. Versuche, den Widerstand, die Dauer und die Anstrengung, die du in jedes Training steckst, schrittweise zu erhöhen, da diese Faktoren dir beim Abnehmen helfen werden.



Abb. 4



Abb. 5



Abb. 6



Abb. 7



Abb. 8



Abb. 9

## HERSTELLERGARANTIE

📌 DIE BLUEFIN GARANTIE DECKT ALLE TECHNISCHE FEEHLER DEINES ARTIKELS AB. WENN DU EINEN GARANTIEANSPRUCH GELTEND MACHEN MUSST, KONTAKTIERE UNS VIA EMAIL AT: [SUPPORT@BLUEFINTRADING.CO.UK](mailto:SUPPORT@BLUEFINTRADING.CO.UK)

DEINE GARANTIE DECKT NICHT DIE FOLGENDEN PUNKTE AB:

- Allgemeine Abnutzung und Gebrauchsspuren.
- Wasserschäden.
- Schäden durch unsachgemäßen Gebrauch.
- Gehäuseschäden und Kratzer durch unsachgemäßen Gebrauch oder Fallenlassen.
- Elektronische Schäden durch unsachgemäßen Gebrauch oder Fallenlassen.
- Deine Garantie beginnt mit dem Erhalt der Lieferung.
- Technische Defekte sind für 12 Monate abgedeckt.

Wenn du Fragen zu deiner Garantie hast, sende uns bitte eine E-Mail an: [support@bluefintrading.co.uk](mailto:support@bluefintrading.co.uk)



William Vaughan, CEO  
Bluefin Trading Ltd.

## EU-KONFORMITÄTSERKLÄRUNG

Für die neueste & aktuellste EU-Konformitätserklärung für dieses Produkt, besuche bitte die folgende Seite:

[www.bluefinfitness.com/manuals/bladeaqua\\_m1\\_DoC.pdf](http://www.bluefinfitness.com/manuals/bladeaqua_m1_DoC.pdf)

Importer Address:

Bluefin Trading Ltd

Keelham Farm

Hebden Bridge

UK

HX7 8TG

[www.bluefinfitness.com](http://www.bluefinfitness.com)



### ELEKTRO- UND ELEKTRONIK-ALTGERÄTE

Dieses Gerät darf nicht mit dem Hausmüll entsorgt werden. Die Komponenten des Geräts müssen separat recycelt oder entsprechend den örtlichen Vorschriften entsorgt werden. Der Systembetreiber kann auch alle Elektro- und Elektronik-Altgeräte am Ende ihrer Lebensdauer an den Hersteller zurückgeben. Die anfallenden Kosten für den Transport zum Hersteller werden Die Kosten für den Transport zum Hersteller gehen zu Lasten des Eigentümers der Elektro- und Elektronik-Altgeräte.



### BATTERIEVERORDNUNG

Entsorge keine Batterien mit dem Hausmüll. Bitte recycle oder entsorge die Batterien entsprechend den örtlichen Vorschriften. Alle vom Hersteller oder Vertreter gelieferten Batterien können am Ende ihrer Lebensdauer zum Recycling und zur sicheren Entsorgung zurückgegeben werden. Die Kosten für den Transport zum Hersteller oder Vertreter gehen zu Lasten des Besitzers der Batterien.



### RECYCLING VON VERPACKUNGSMATERIALIEN

Entsorge die Verpackungen nicht mit dem Hausmüll. Alle Verpackungsmaterialien können gemäß den örtlichen Vorschriften sicher recycelt werden.

# BLADE AQUA

M-1 WATER RESISTANCE ROWER

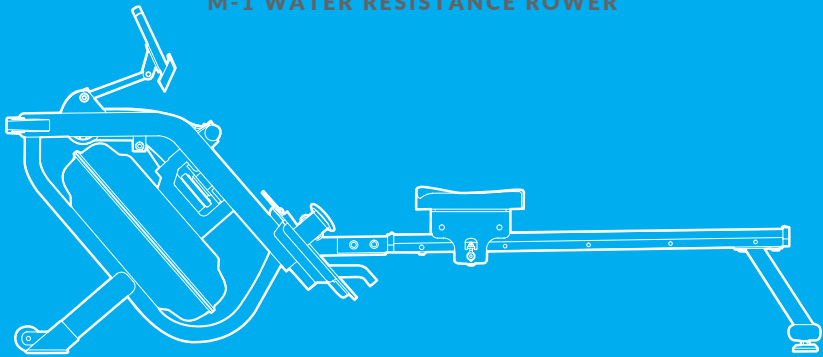



## TE DAMOS LA BIENVENIDA A LA COMUNIDAD DE BLUFIN FITNESS

QUERIDO CLIENTE:

GRACIAS POR ESCOGER LA MÁQUINA DE REMO BLADE AQUA M-1 DE BLUEFIN FITNESS. PARA SACAR EL MEJOR PARTIDO DE TU NUEVA MÁQUINA DE REMO, POR FAVOR, ASEGÚRATE DE QUE TODAS LAS PERSONAS QUE VAYAN A USAR ESTE EQUIPO LEEN ATENTAMENTE Y COMPRENDEN EL SIGUIENTE MANUAL ANTES DE USARLA.

BLUEFIN FITNESS NO SE RESPONSABILIZA DE NINGÚN DAÑO CAUSADO POR SU USO INAPROPIADO O INCORRECTO.

ESPERAMOS QUE DISFRUTES DE TU NUEVA MÁQUINA DE REMO BLADE AQUA M-1. SI TIENES INTERÉS EN PONERTE AL DÍA SOBRE NUESTRA SIEMPRE CRECIENTE COLECCIÓN DE EQUIPOS DE FITNESS, ECHA UN VISTAZO A NUESTRA WEBSITE: [BLUEFINFITNESS.COM](https://bluefinfitness.com) Y SÍGUENOS EN LAS REDES SOCIALES:

**FACEBOOK** [FACEBOOK.COM/BLUEFINFITNESS](https://facebook.com/bluefinfitness)

**INSTAGRAM** [@BLUEFINFITNESS](https://instagram.com/bluefinfitness)

**TWITTER** [@BLUEFIN\\_FITNESS](https://twitter.com/bluefin_fitness)

**LINKEDIN** [LINKEDIN.COM/BLUEFIN-FITNESS](https://linkedin.com/company/bluefin-fitness)

EL EQUIPO DE BLUEFIN FITNESS

## MEDIDAS DE SEGURIDAD

**i** COMO HEMOS DICHO ANTES, POR FAVOR, ASEGURATE DE QUE TODAS LAS PERSONAS QUE VAYAN A USAR LA BLADE AQUA HAN LEIDO Y COMPRENDIDO ESTE MANUAL ANTES DE USARLA.

**TE RECOMENDAMOS GUARDAR ESTE MANUAL PARA FUTURAS CONSULTAS.**

La siguiente información sobre medidas de seguridad debe ser respetada cuando se usa la Blade Aqua.

- Siempre consulta a tu médico antes de comenzar cualquier programa de ejercicios, teniendo en cuenta cualquier dificultad médica o física que pueda poner en riesgo tu salud y seguridad, especialmente si estás tomando alguna medicación para el corazón, presión sanguínea o control de los niveles de colesterol.
- Deja el ejercicio inmediatamente si notas alguno de estos síntomas mientras haces ejercicio: dolor agudo, presión en el pecho, ritmo cardiaco irregular, dificultad respiratoria, mareos o náuseas. Si notas alguno de los anteriores síntomas, consulta a tu médico antes de seguir haciendo ejercicio.
- Mantén siempre alejados de la máquina de remo a niños y mascotas. Está hecha para su uso sólo por adultos.
- Coloca el equipo sobre una superficie sólida, lisa y nivelada, mejor con una esterilla de protección para cuidar el suelo. Asegúrate siempre de que hay un espacio de al menos 60cm libres alrededor del equipo.
- Asegúrate de que todas las tuercas y pernos están bien ajustados antes de usar el equipo.
- Examina regularmente el equipo por si hubiera cualquier daño o desgaste para mantener las condiciones de seguridad generales.

- Si encuentras cualquier pieza defectuosa mientras montas el equipo, o si escuchas que el equipo hace cualquier ruido anormal durante el ejercicio, deja de usar el equipo inmediatamente. No sigas usando el equipo hasta que el problema se haya resuelto.
- Lleva ropa adecuada para hacer ejercicio cuando uses el equipo. Evita llevar ropa floja que pueda engancharse.
- No metas los dedos u objetos pequeños en las partes móviles del equipo.
- El peso máximo admitido por el equipo son 150kg.
- Desplaza el equipo con consideración y cuidado por ti y por los que te rodean. Busca ayuda si es necesario.
- No expongas el equipo a temperaturas o condiciones extremas, lo cual incluye zonas húmedas, que pueden producir corrosión y problemas de funcionamiento.
- Este equipo ha sido diseñado sólo para usarse en interior y para su uso en el hogar. No está pensado para un uso comercial.

**⚠ AVISO: SI ERES MAYOR DE 45 AÑOS O SI TIENES ALGÚN PROBLEMA DE SALUD, POR FAVOR, CONSULTA A TU MÉDICO ANTES DE USAR EL EQUIPO.**

**BLUEFIN FITNESS NO SE RESPONSABILIZA DE LESIONES O DAÑOS MATERIALES DEBIDOS AL USO DE ESTE PRODUCTO.**

## LISTA DE HERRAJES

**i** ANTES DE INSTALAR LA BLADE AQUA M-1, ASEGÚRATE DE QUE LAS SIGUIENTES PIEZAS ESTÁN INCLUIDAS:

NOTA: ALGUNAS PIEZAS PEQUEÑAS PUEDEN HABER SIDO FIJADAS CON ANTELACIÓN A LAS PIEZAS MÁS GRANDES PARA AYUDARTE EN EL MONTAJE.



19 x1



20 x1



80 M8 x1



59 M8\*15 x4



61 M4\*12 x2



62 M8\*15 x4



68 M8\*15 x8



72 M6\*10 x2



66 M8\*65 x4



74 OD20\*ID8.5\*1.5 x8

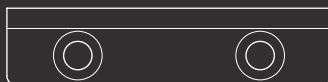

40 x1



93 S5 x1



94 S13-17 x1

## LISTA PARA EL MONTAJE

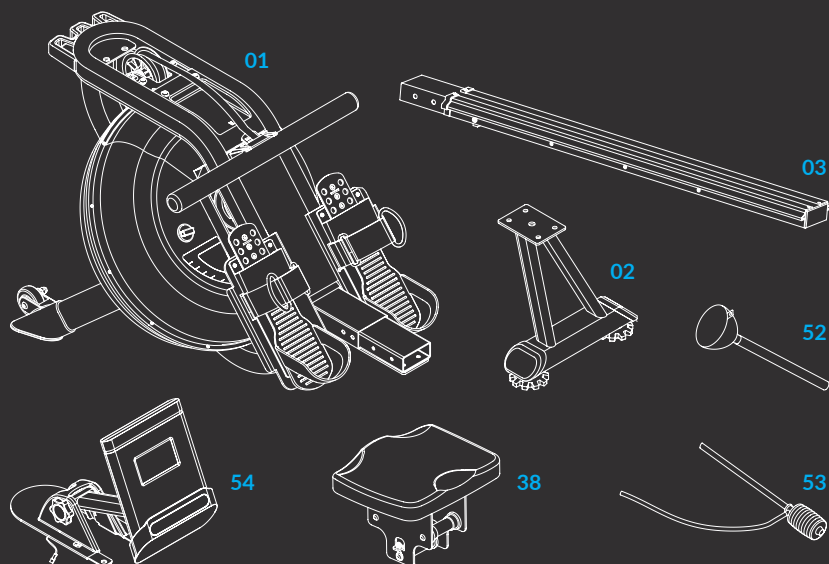

PIEZA	DESCRIPCIÓN	CANTIDAD
01	Estructura Principal	x1
02	Estabilizador Trasero	x1
03	Rail deslizante	x1
38	Asiento	x1
52	Embudo	x1
53	Sifón de Bombeo	x1
54	Ordenador	x1

# 01

## INSTRUCCIONES DE MONTAJE

**ⓘ** NOTA: RECOMENDAMOS QUE DOS PERSONAS PARTICIPEN EN EL MONTAJE.

- Desliza el Asiento **38** sobre el Rail Deslizante **03**.
- Fija el Tope **40** con x2 Tornillos de Cruz Planos **72**.
- Une el Estabilizador Trasero **02** al Rail Deslizante **03** con x4 Arandelas **74** y x4 Tornillos Hexagonales **59**.
- Ajústalos con la Llave Inglesa **94**.



**72** M6\*10 **x2**



**59** M8\*15 **x4**



**94** S13-17 **x1**



**74** OD20\*ID8.5\*1.5 **x4**

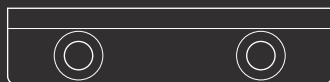

**40** **x1**

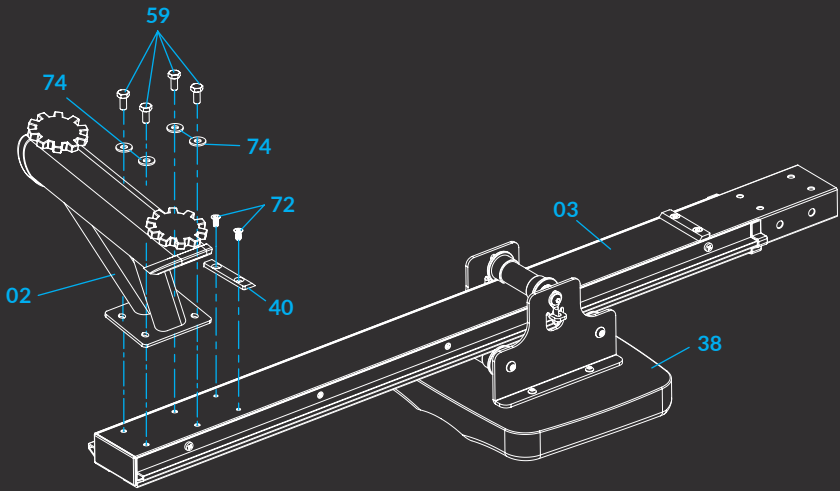

# 02

## INSTRUCCIONES DE MONTAJE

- Fija el Embellecedor Izquierdo/Derecho del Rail **19** y **20** con **x2** Tornillos de Cruz **61** al Rail Deslizante **03**.  
Ajústalos con la Llave Inglesa **94**.



**19 x1**



**20 x1**



**61 M4\*12 x2**



**94 S13-17 x1**

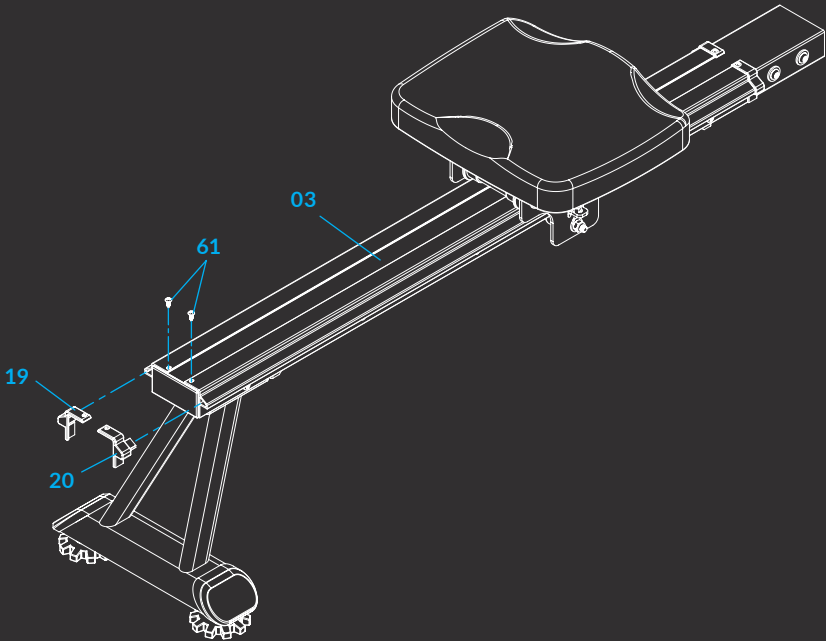

# 03

## INSTRUCCIONES DE MONTAJE

① MUEVE EL ASIENTO 38 HACIA EL EXTREMO DELANTERO DEL RAIL DESLIZANTE 03 ANTES DEL MONTAJE PARA EVITAR QUE SE MUEVA DURANTE EL MONTAJE.

- Une el Rail Deslizante 03 a la Estructura Principal 01 con x4 Arandelas 74, x4 Tornillos 68 y x4 Tornillos Planos 62.
- Inserta primero parcialmente los 8 tornillos en sus agujeros y, después, ajústalos con la Llave Allen 93.



62 M8\*15 x4



68 M8\*15 x4



74 OD20\*ID8,5\*1,5 x4



93 S5 x1

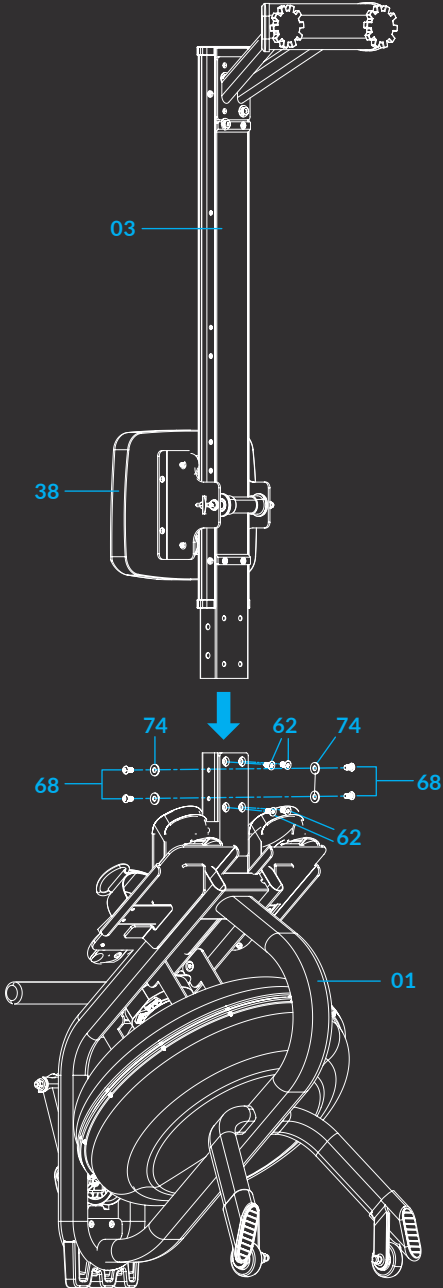

# 04

## INSTRUCCIONES DE MONTAJE

- Segundo, une el soporte de la **Consola 54** a la **Estructura Principal 01**, asegurándote de que los cables están conectados. Después ajusta con **x4 Tornillos 68** y la **Llave Allen 93**.



66 M8\*65 **x4**



80 M8 **x1**



94 S13-17 **x1**



93 S5 **x1**



74 OD20\*ID8.5\*1.5 **x2**

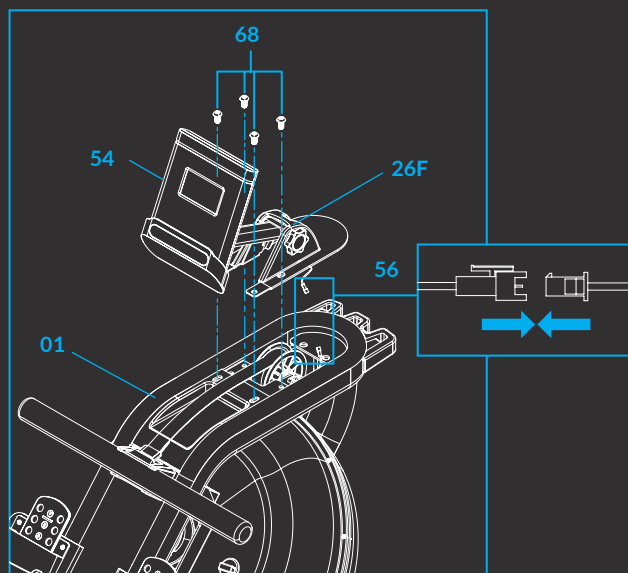

Desbloqueo



Bloqueo

Para aflojar gira en dirección contraria a las agujas del reloj tres vueltas, ajusta el ángulo de la **Consola 54** y después gira en dirección de las agujas del reloj para fijarla.

# 05

## DEPÓSITO DE AGUA

NO USES NUNCA CLORO DE PISCINAS NI LEJÍA PARA LLENAR EL DEPÓSITO DE AGUA YA QUE DAÑARÍAN EL DEPÓSITO Y ESTO ANULARÍA LA GARANTÍA.

AÑADE X1 PASTILLA DEPURADORA DE AGUA CADA 2-3 MESES, O SEGÚN SEA NECESARIO. SI EL AGUA SE VUELVE TURBIA, CAMBIA EL AGUA DEL DEPÓSITO.

NO CONSUMAS EL AGUA DEL DEPÓSITO. SIEMPRE CAMBIA EL AGUA DEL DEPÓSITO USANDO LA BOMBA DE SIFÓN Y TÍRALA DE FORMA SEGURA.

### LLENADO Y VACIADO

- Quita el **Tapón de Llenado 50** de la **Tapa Superior del Depósito 24**.
- Para llenar el depósito de agua, mira la **Fig. A**. Inserta el **Embudo 52** en el depósito, después usa una taza o la **Bomba de Sifón 53** y un cubo para llenar el depósito de agua. Usa el visor de nivel de agua situado en el lateral del depósito para medir el nivel de agua deseado.
- Para vaciar el depósito, mira la **Fig. B**.
- Coloca un cubo al lado de la máquina de remo, y usa la **Bomba de Sifón 53** para sacar el agua del depósito y echarla en el cubo.
- Coloca el **Tapón de Llenado 50** en la **Tapa Superior del Depósito 24**. Seca con un paño cualquier resto de agua de la estructura.

Fig. A

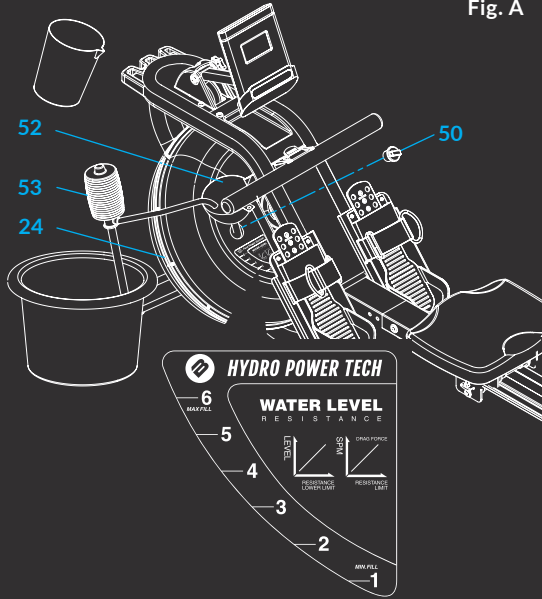
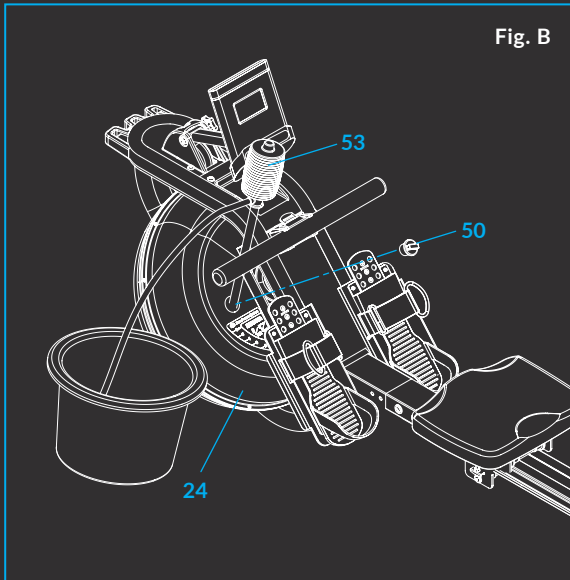

Fig. B



## DEPÓSITO DE AGUA

### CUIDADOS Y MANTENIMIENTO

- Las pastillas depuradoras de agua ayudan a mantener las condiciones óptimas del agua para un uso continuado.
- Debes usar agua destilada para llenar el depósito.
- Cuando hayas puesto una pastilla depuradora de agua en el depósito, empieza a remar para remover la pastilla, asegurándote de que se disuelve en el agua.
- Cada pastilla depuradora de agua contiene unos 167mg de dicloroisocianurato de sodio. Por favor, evita el contacto con objetos de metal para evitar la aparición de corrosión u óxido.



**LAS PASTILLAS DEPURADORAS DE AGUA NO SE INCLUYEN EN ESTE PRODUCTO DEBIDO A LA NORMATIVAS SOBRE ENVÍOS INTERNACIONALES. POR FAVOR, COMPRA LAS PASTILLAS DEPURADORAS DE AGUA A UN VENDEDOR LOCAL DE CONFIANZA O ONLINE.**



## DESPLAZAR TU BLADE AQUA

- Para desplazar la máquina de remo, levanta el **Soporte Trasero 02** hasta que las **Ruedas Móviles 18** del estabilizador delantero toquen el suelo.
- Con las ruedas sobre el suelo, suavemente empuja y desplaza la máquina de remo al lugar que quieres con facilidad.

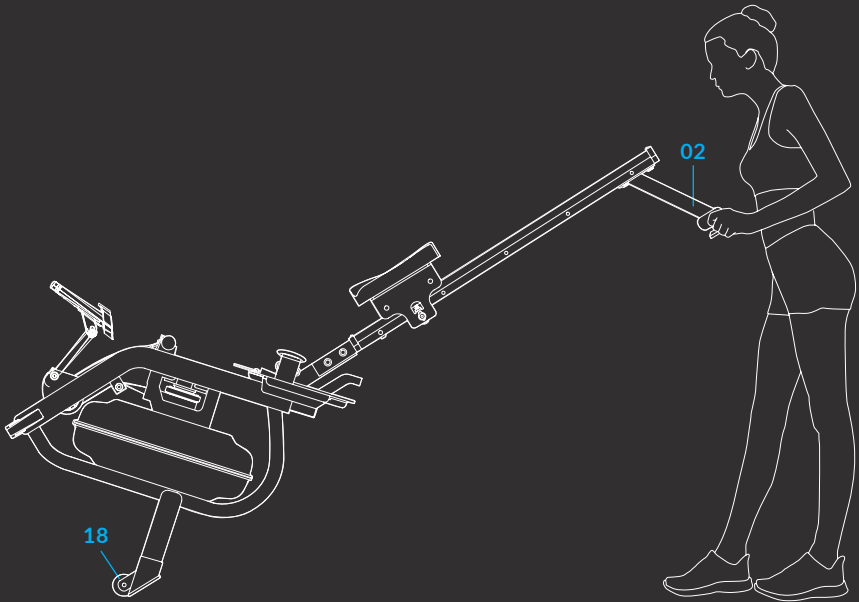

## ESTABILIZAR TU BLADE AQUA

**⚠ ¡ATENCIÓN!: MANTÉN LAS MANOS ALEJADAS DE LOS RAILES DESLIZANTES LATERALES CUANDO ESTÉS AJUSTANDO TU BLADE AQUA YA QUE EL MOVIMIENTO DEL ASIENTO TE PUEDE PRODUCIR ALGUNA LESIÓN.**

- Si sientes que la máquina está desequilibrada durante su uso, ajusta la **Rueda de Ajuste 23** situada bajo el **Estabilizador Trasero 02** de la máquina para estabilizarla.

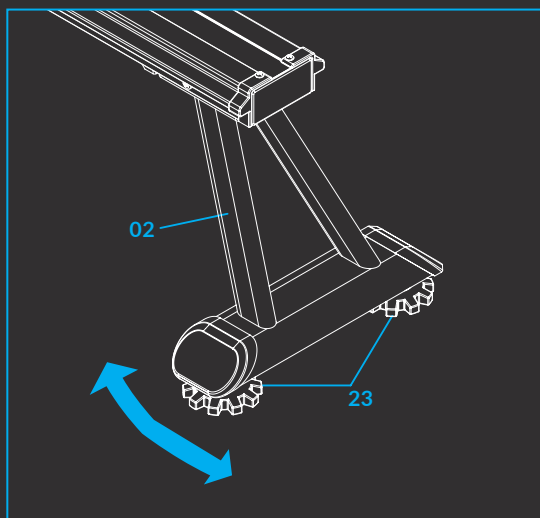

## GUARDAR TU BLADE AQUA

⚠ **NOTA: ASEGÚRATE DE DESLIZAR EL ASIENTO 38 HASTA EL EXTREMO DELANTERO DEL RAIL LATERAL 3 CUANDO LEVANTES LA MÁQUINA PARA QUE EL ASIENTO NO SE MUEVA DURANTE SU TRANSPORTE.**

⚠ **CON CUIDADO, DOBLA EL RAIL LATERAL HACIA ARRIBA, ASEGURÁNDOTE DE QUE TÚ Y CUALQUIERA QUE ESTÉ A TU LADO NO PUEDA SUFRIR NINGÚN DAÑO.**

- Cuando no la uses, ahorra espacio guardando la máquina de remo en posición vertical. Para hacerlo, levanta el **Estabilizador Trasero 02** y empuja la máquina hacia arriba.
- Si no tienes pensado usar la máquina de remo durante más de un mes, vacía el depósito de agua antes de guardarla.

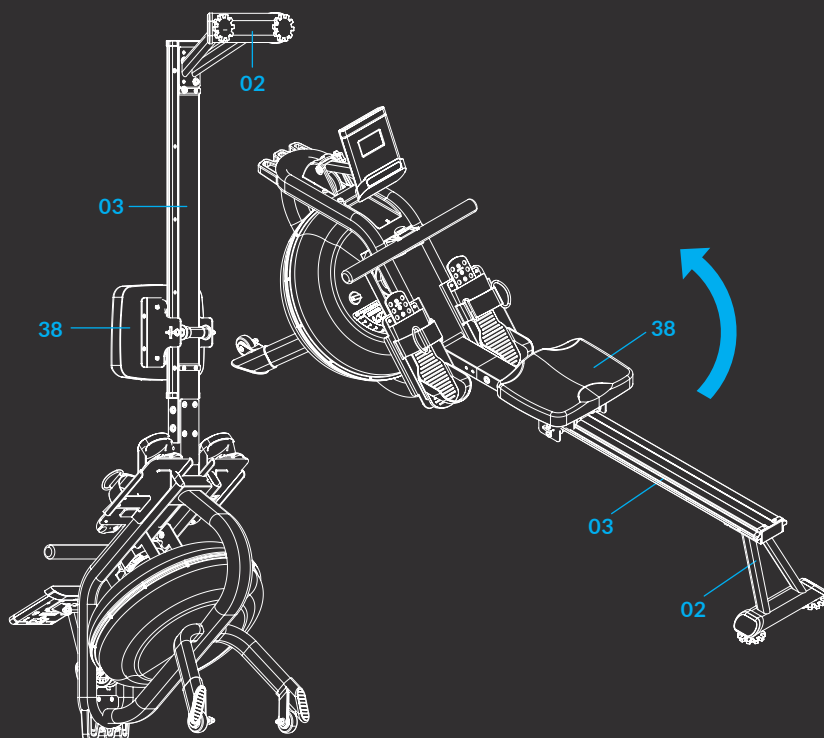



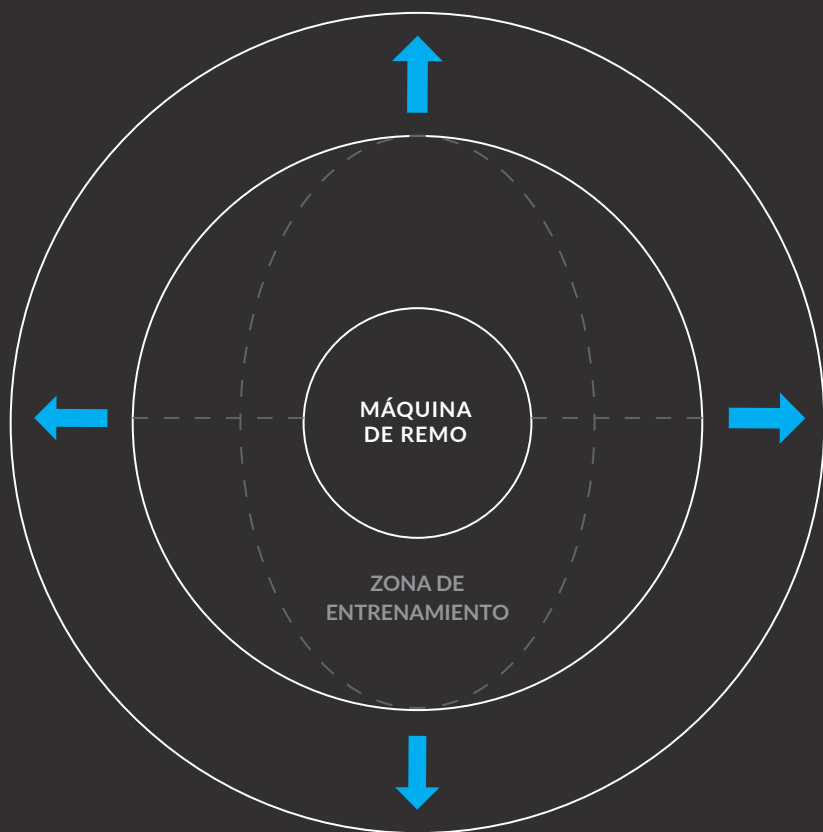

0,6 METROS DE ZONA LIBRE

# FUNCIONES DE LA CONSOLA

## BOTONES DE FUNCIONES

<b>MODO</b>	Pulsa para seleccionar las funciones. Pulsa durante 2 segundos para resetear Tiempo/Cuenta/ Distancia y Calorías
<b>SET</b>	Para seleccionar los valores de Tiempo/Cuenta/Distancia/ Calorías y Ritmo Cardíaco cuando no estás en modo scan.
<b>RESET</b>	Pulsa para resetear Tiempo/Cuenta/Distancia/Calorías y Ritmo Cardíaco.

## FUNCIONES Y USO

Presiona la tecla MODE, selecciona TIME, aparecerá la palabra 'SCAN' a la izquierda de la pantalla. Entonces aparecerán las 6 funciones en la pantalla durante 6 segundos cada una: TIME, COUNT, DISTANCE, CALORIES, RPM y PULSE.

Cuando aparezca en la pantalla la función que quieres seleccionar, presiona la tecla MODE para elegir esta función y selecciona los parámetros que quieres medir durante el ejercicio.

<b>TIME</b>	Muestra durante cuánto tiempo has estado haciendo ejercicio.
<b>COUNT</b>	Muestra la cantidad de paladas que has realizado.
<b>DISTANCE</b>	Muestra la distancia que has recorrido durante el ejercicio, desde el principio hasta el final.
<b>CALORIES</b>	Muestra la cantidad de calorías quemadas durante el ejercicio.
<b>RPM</b>	Muestra el numero de paladas que realizas por minuto.
<b>PULSE</b>	Muestra tu ritmo cardiaco durante el ejercicio. <i>También se puede usar la cinta de pecho sensora de ritmo cardiaco para obtener una lectura más precisa del ritmo cardiaco.</i>

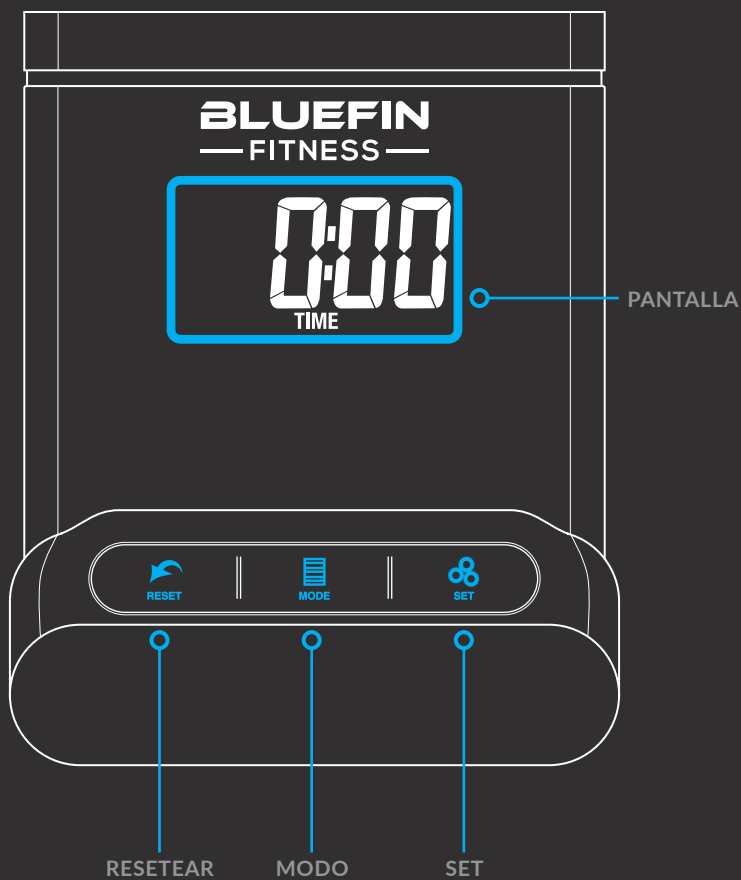

# USO DE LA CONSOLA

## MODOS DE ENTRENAMIENTO CON UN OBJETIVO

Esta consola tiene cinco modos de entrenamiento con un objetivo: Tiempo, Cuenta, Distancia, Calorías y Ritmo Cardíaco. Cuando hayas elegido tu modo de entrenamiento, presiona la tecla MODE para hacer que SCAN deje de parpadear en la pantalla.

**TIEMPO** Presiona la tecla MODE, selecciona TIME, y presiona la tecla SET para programar la duración del ejercicio. Cuando empieces a entrenar en la máquina de remo, el contador se pondrá en marcha en cuenta regresiva desde el tiempo seleccionado. Cuando el objetivo del entrenamiento se ha alcanzado, la consola emitirá un pitido para señalar el final del entrenamiento. Si sigues entrenando después de alcanzar este punto, la pantalla automáticamente empezará a contar desde cero.

**CUENTA** Presiona la tecla MODE, selecciona COUNT y presiona la tecla SET para programar el número de paladas completas que quieres alcanzar. Puedes presionar y mantener presionada la tecla SET para acelerar la búsqueda. Cuando hayas alcanzado el número deseado, deja de presionar la tecla. Cuando empieces a entrenar en la máquina de remo, la pantalla se pondrá en marcha en cuenta regresiva desde el valor seleccionado. Cuando el objetivo del entrenamiento se haya alcanzado, la consola emitirá un pitido para señalar el final del entrenamiento. Si continúas entrenando después de alcanzar este punto, la pantalla automáticamente empezará a contar desde cero.

**DISTANCIA** Presiona la tecla MODE, selecciona DISTANCE y presiona la tecla SET para programar la distancia virtual que quieres alcanzar. Puedes presionar y mantener presionada la tecla SET para acelerar la búsqueda. Cuando hayas alcanzado la distancia deseada, deja de presionar la tecla. Cuando empieces a entrenar en la máquina de remo, la pantalla se pondrá en marcha en cuenta regresiva desde el valor seleccionado. Cuando el objetivo del entrenamiento se haya alcanzado, la consola emitirá un pitido para señalar el final del entrenamiento. Si continúas entrenando después de alcanzar este punto, la pantalla automáticamente empezará a contar desde cero.

**CALORIAS** Presiona la tecla MODE, selecciona CALORIES y presiona la tecla SET para programar la cantidad de calorías que quieres quemar durante el ejercicio. Puedes presionar y mantener presionada la tecla SET para acelerar la búsqueda. Cuando hayas alcanzado la cantidad de calorías deseada, deja de presionar la tecla. Cuando empieces a entrenar en la máquina de remo, la pantalla se pondrá en marcha en cuenta regresiva desde el valor seleccionado. Cuando el objetivo del entrenamiento se haya alcanzado, la consola emitirá un pitido para señalar el final del entrenamiento. Si continúas entrenando después de alcanzar este punto, la pantalla automáticamente empezará a contar desde cero.

**PULSO** Presiona la tecla MODE, selecciona PULSE y presiona la tecla SET para programar el ritmo cardíaco que quieres alcanzar durante el ejercicio. Puedes presionar y mantener presionada la tecla SET para acelerar la búsqueda. Cuando hayas alcanzado el valor de ritmo cardíaco deseado, deja de presionar la tecla. Cuando empieces a entrenar en la máquina de remo, la pantalla se pondrá en marcha en cuenta regresiva desde el valor seleccionado. Cuando el objetivo del entrenamiento se haya alcanzado, la consola emitirá un pitido para señalar el final del entrenamiento. Si continúas entrenando después de alcanzar este punto, la pantalla automáticamente empezará a contar desde cero.

**Puedes cambiar siempre los objetivos programados de tu entrenamiento presionando la tecla RESET para borrar los valores actuales. Después puedes elegir otra vez tus objetivos del entrenamiento siguiendo las instrucciones anteriores.**

## USO DE LA CONSOLA

NOTA: SI LA PANTALLA SE DESVANECE O NO MUESTRA LOS NÚMEROS, POR FAVOR, CAMBIA LAS BATERÍAS DE LA PANTALLA.

LA CONSOLA SE APAGARÁ AUTOMÁTICAMENTE SI NO RECIBE NINGUNA SEÑAL DURANTE 4 MINUTOS.

EL MONITOR SE ENCENDERÁ AUTOMÁTICAMENTE CUANDO EMPIECES A USAR LA MÁQUINA DE REMO.

EL MONITOR EMPEZARÁ AUTOMÁTICAMENTE A CALCULAR TU ENTRENAMIENTO EN CUANTO EMPIECES A REMAR, Y HASTA 4 MINUTOS DESPUÉS DE QUE TERMINES.

FUNCIÓN	SCAN	cada 6 segundos
	TIEMPO	0:00~99:59
	CUENTA	0~9999 VECES
	DISTANCIA	0~9999 METRPS
	CALORÍAS	0.0~999.9 CAL
	RPM	0~999 VECES-MIN
	PULSO	40~220 BPM
TIPO DE BATERÍA	2 pilas TAMAÑO -AA o UM-3	
TEMPERATURA DE USO	0°C~ +40°C	
TEMPERATURA GUARDADA	-10°C~ +60°C	



## APP KINOMAP FITNESS

### DESCARGAR LA APLICACIÓN

- Busca Kinomap en la app store de tu smartphone y descárgala.
- Cuando se haya completado la descarga, abre la app KINOMAP y registra tus datos personales.
- Enciende el Bluetooth y comprueba que la Blade Aqua está encendida y en estado conectada.
- Sincroniza tu Blade Aqua con la app KINOMAP como sigue:



## 01

Presiona More para que aparezca la página Equipment, selecciona **Equipment Management** (control del equipo)

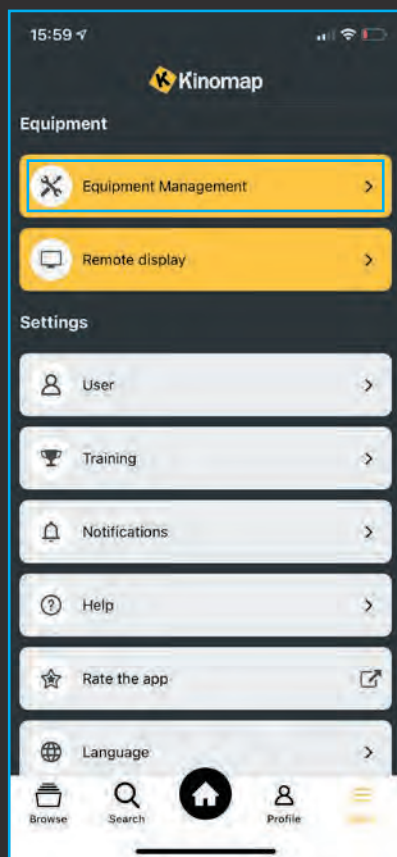

## 02

Presiona el símbolo +.

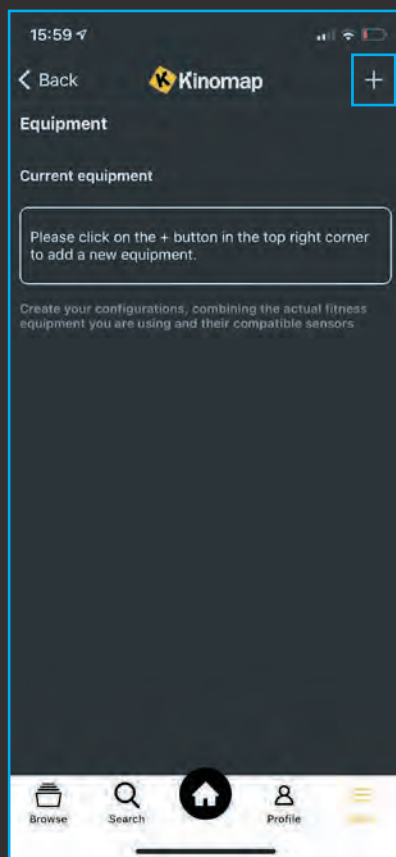

# 03

Selecciona el icono **Rowing** (remar).



# 04

Selecciona el icono de **Bluefin Fitness**.

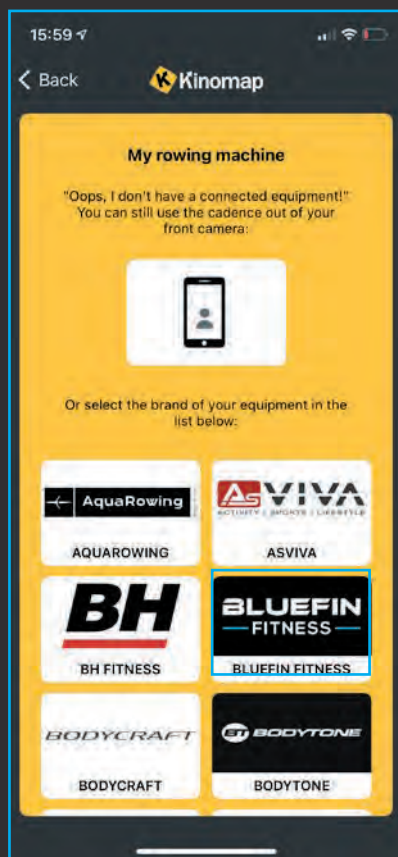

## 05

Selecciona **Blade Aqua M-1**.

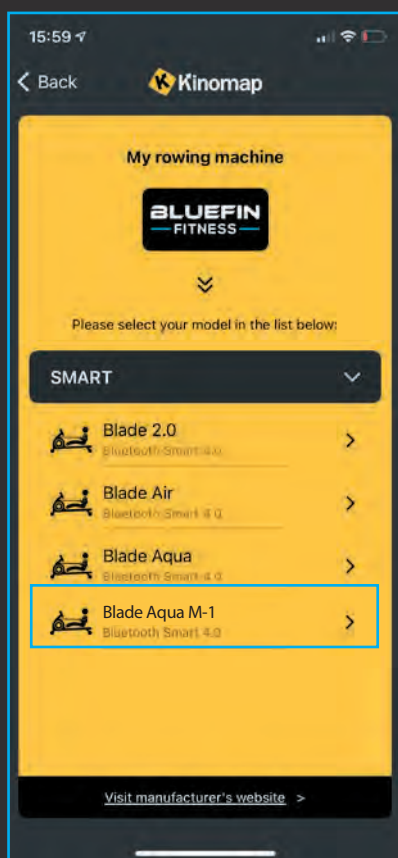

## 06

Añade tu **Blade Aqua M-1** para terminar y comienza tus ejercicios.

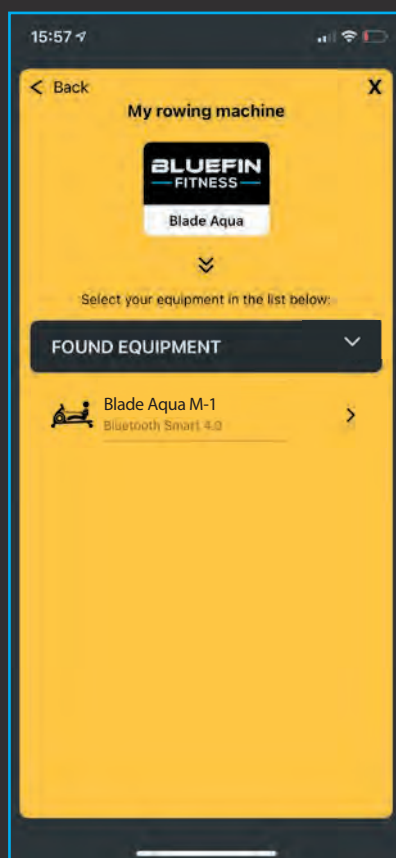

## CALENTAR Y ENFRIAR

PARA EVITAR LESIONES, SIEMPRE DEBERÍAS CALENTAR Y ENFRIAR CON VARIOS ESTIRAMIENTOS ANTES Y DESPUÉS DE CADA ENTRENAMIENTO.

TE RECOMENDAMOS LOS SIGUIENTES ESTIRAMIENTOS, QUE REDUCIRÁN EL RIESGO DE LESIONES MUSCULARES O CALAMBRES DURANTE EL EJERCICIO. NUNCA ESTIRES EN EXCESO NI FUERCES TUS MÚSCULOS.

### FLEXIÓN LATERAL

Pasa un brazo por encima de tu cabeza flexionando tu cuerpo lateralmente en la misma dirección. Mantén esta posición durante 10 o 15 segundos y poco a poco vuelve a la posición de inicio. Repítelo 3 veces por cada lado.

### TOCAR LO DEDOS DE LOS PIES

Lentamente, flexiona por la cintura hacia adelante, con la espalda y los hombros relajados mientras te estiras hacia los dedos de tus pies. Intenta bajar tanto como puedas y mantén la posición durante 15 segundos. Después relaja y repite 3 veces.

## ESTIRAMIENTO DE GEMELOS

Apóyate contra una pared con la pierna izquierda por delante de la derecha y tus manos sobre la pared. Mantén la pierna derecha recta y tu pie izquierdo plano sobre el suelo, dobla la pierna izquierda hacia adelante moviendo tus caderas hacia la pared. Mantén la posición durante 15 segundos, después repite con la otra pierna. Repite 3 veces con cada pierna.

## ESTIRAMIENTO DE CUÁDRICEPS

Con una mano apoyada en la pared para mantener el equilibrio, coge tu pie derecho por detrás de tu espalda y tira de él hacia arriba. Tira de tu pie acercando el talón a los glúteos tanto como puedas. Mantén la posición durante 15 segundos. Repite 3 veces con cada pie.

## ESTIRAMIENTO DE MUSLO INTERIOR

Siéntate en el suelo con las plantas de tus pies juntas y las rodillas apuntando hacia el exterior. Tira de tus pies para colocarlos tan cerca de tus ingles como puedas. Con suavidad empuja tus rodillas hacia el suelo. Mantén la posición durante 15 segundos. Después relaja y repite 3 veces.

## EJERCICIOS DE REMO

### USANDO REGULARMENTE TU MÁQUINA DE REMO CONSEGUIRÁS:

- Mejorar tu forma física general, fortaleciendo el corazón y mejorando la circulación sanguínea y también ejercitando los grupos musculares de espalda, cintura, brazos, hombros, caderas y piernas.
- Tonificar los músculos y, junto con una dieta de control de calorías, te ayudará a perder peso. Remar es una forma extremadamente efectiva de hacer ejercicio.

### LA PALADA BÁSICA PARA REMAR

- Siéntate en el asiento y abrocha tus pies a los pedales con las correas. Después sujeta la barra del remo.
- Toma la posición de inicio, inclínandote hacia adelante con tus brazos estirados y las rodillas dobladas como se muestra en la Fig 1.
- Empuja de ti hacia atrás enderezando la espalda y las piernas al mismo tiempo Fig2.
- Continúa este movimiento hasta que te inclines ligeramente hacia atrás durante esta fase tus brazos deberían sobresalir por los laterales Fig 3. Después vuelve a la fase 2 y repite.

### ENTRENAMIENTO

- Remar es un ejercicio enérgico, así que es mejor empezar a entrenar con una resistencia baja y durante periodos cortos de tiempo si eres principiante. Mientras vas mejorando, puedes ir aumentando el nivel de resistencia y el tiempo de entrenamiento según tus necesidades y tus objetivos en el fitness. Te recomendamos empezar a entrenar cada dos días, aproximadamente 3 veces por semana, para darle tiempo a tu cuerpo a recuperarse entre los entrenamientos.

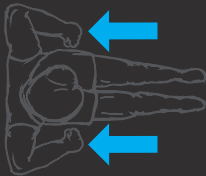

Fig 1



Fig 2



Fig 3

## EJERCICIOS DE REMO

### EJERCICIOS DE REMOS ALTERNATIVOS

#### REMAR SÓLO CON BRAZOS

Este estilo de remo tonificará los músculos de los brazos, hombros, espalda y estómago. Siéntate como se muestra en la **Fig 4** con tus piernas rectas, inclinado hacia adelante y sujeta la barra. De forma gradual y controlada, échate hacia atrás sobrepasando ligeramente la posición recta y continúa tirando de la barra hacia tu pecho. Vuelve a la posición inicial y repite.

#### REMAR SÓLO CON PIERNAS

Este ejercicio tonificará los músculos de las piernas y espalda. Con la espalda recta y los brazos estirados, dobla las piernas hasta que cojas la barra como en la posición inicial, **Fig 7**. Usa las piernas para empujar tu cuerpo hacia atrás mientras mantienes los brazos y espalda rectos.

#### TONIFICACIÓN MUSCULAR.

La forma más eficaz de tonificar tus músculos mientras remas es seleccionar una resistencia alta, pero teniendo siempre en mente no causarte una lesión por ejercitar en exceso tus músculos. Te recomendamos siempre calentar y enfriar con una resistencia baja y aumentar la resistencia en la fase final de tu entrenamiento, cuando tus músculos se hayan calentado bien.

#### PERDER PESO

Cuanto más esfuerzo pongas en tus ejercicios de remo, más calorías quemarás. Mira de aumentar gradualmente la resistencia, duración y esfuerzo en cada ejercicio ya que estos factores te ayudarán a perder peso.



Fig 4



Fig 5



Fig 6



Fig 7



Fig 8



Fig 9

## GARANTÍA DEL FABRICANTE

📌 LA GARANTÍA DE BLUEFIN CUBRE CUALQUIER DEFECTO TÉCNICO DE TU ARTÍCULO. SI NECESITAS HACER UNA RECLAMACIÓN, MÁNDANOS UN EMAIL A: [SUPPORT@BLUEFINTRADING.CO.UK](mailto:SUPPORT@BLUEFINTRADING.CO.UK)

### LA GARANTÍA NO CUBRE LO SIGUIENTE:

- Desgaste por uso y marcas debidas al uso.
- Daños por agua.
- Daños debidos a un uso inapropiado.
- Daños en la estructura y arañazos debidos a un uso inapropiado o caída.
- Daños en la parte electrónica debidos a un uso inapropiado o caída.
- La garantía empieza a contar desde el momento de recepción del artículo.
- Los defectos técnicos están cubiertos durante 12 meses.

Si tienes alguna duda sobre la garantía, por favor, mándanos un email a: [support@bluefintrading.co.uk](mailto:support@bluefintrading.co.uk)



William Vaughan, CEO  
Bluefin Trading Ltd.

## EU DECLARATION OF CONFORMITY

Para ver la última y actualizada declaración de conformidad de la UE para este producto, por favor, visita:

[www.bluefinfitness.com/manuals/bladeaqua\\_m1\\_DoC.pdf](http://www.bluefinfitness.com/manuals/bladeaqua_m1_DoC.pdf)

Importer Address:

Bluefin Trading Ltd

Keelham Farm

Hebden Bridge

UK

HX7 8TG

[www.bluefinfitness.com](http://www.bluefinfitness.com)



### WASTE ELECTRICAL & ELECTRONIC EQUIPMENT

No tires esta máquina junto con los residuos domésticos. Los componentes de esta máquina deben ser reciclados por separado de acuerdo con las normativas locales. El usuario de la máquina también puede devolver cualquier residuo de un equipo eléctrico o electrónico al fabricante al final de su vida útil. Los gastos derivados de su devolución al fabricante correrán a cargo del dueño de los residuos del equipo eléctrico o electrónico.



### DIRECTIVA SOBRE PILAS Y BATERÍAS.

No tires las pilas y baterías junto con los residuos domésticos. Por favor, recicla o tira las pilas de acuerdo con la normativa local. Cualquier pila o batería suministrada por el fabricante o distribuidor puede ser devuelta al final de su vida útil para su reciclaje o su eliminación de forma segura. Los gastos derivados de la devolución al fabricante o distribuidor correrán a cargo del dueño de las pilas o baterías.



### RECICLADO DE LOS MATERIALES DE EMBALAJE

No tires el embalaje junto con los residuos domésticos. Todos los materiales del embalaje se pueden reciclar de forma segura según las normativas locales.

# BLADE AQUA



M-1 WATER RESISTANCE ROWER

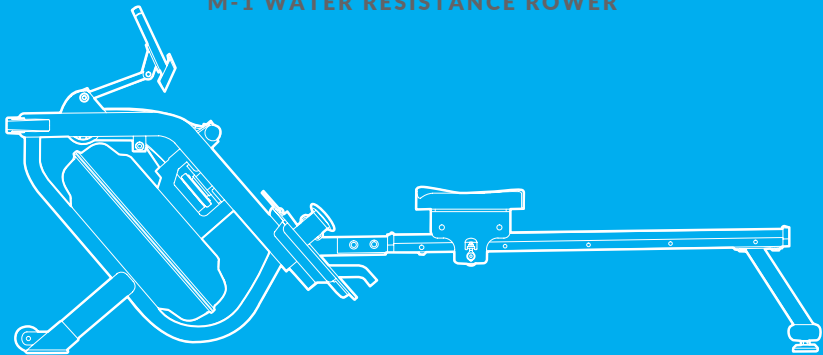



## WELCOME TO THE BLUEFIN FITNESS COMMUNITY

DEAR CUSTOMER

THANK YOU FOR CHOOSING THE BLUEFIN FITNESS BLADE AQUA M-1 ROWING MACHINE. TO ENSURE YOU GET THE MOST OUT OF YOUR NEW ROWER, PLEASE ENSURE THAT ALL PERSONS USING THE EQUIPMENT READ AND UNDERSTAND THE FOLLOWING MANUAL CAREFULLY BEFORE USE.

BLUEFIN FITNESS ASSUMES NO LIABILITY FOR DAMAGES CAUSED BY IMPROPER USE OR INCORRECT OPERATION.

WE HOPE YOU ENJOY USING YOUR NEW BLADE AQUA M-1 ROWING MACHINE. SHOULD YOU BE INTERESTED IN KEEPING UP WITH OUR EVER-GROWING FITNESS EQUIPMENT RANGE, TAKE A LOOK AT OUR WEBSITE [BLUEFINFITNESS.COM](https://www.bluefinfitness.com) AND FOLLOW US ON OUR SOCIALS:

**FACEBOOK** [FACEBOOK.COM/BLUEFINFITNESS](https://www.facebook.com/bluefinfitness)

**INSTAGRAM** [@BLUEFINFITNESS](https://www.instagram.com/bluefinfitness)

**TWITTER** [@BLUEFIN\\_FITNESS](https://twitter.com/bluefin_fitness)

**LINKEDIN** [LINKEDIN.COM/BLUEFIN-FITNESS](https://www.linkedin.com/company/bluefin-fitness)

THE BLUEFIN FITNESS TEAM

## SAFETY PRECAUTIONS

**i AS PREVIOUSLY MENTIONED, PLEASE ENSURE THAT ALL PERSONS USING THE BLADE AQUA HAVE READ AND UNDERSTOOD THIS MANUAL BEFORE USE.**

**WE RECOMMEND YOU KEEP THIS MANUAL FOR FUTURE REFERENCE.**

**The following general safety information must be observed when using the Blade Aqua M-1.**

- Always consult your physician before starting any exercise program, considering any medical or physical conditions that may put your health and safety at risk, especially if you are taking any medication for your heart, blood pressure or cholesterol levels.
- Stop exercising immediately if you experience any of the following whilst exercising: sharp pain, tightness in your chest, irregular heartbeat, shortness of breath, dizziness, or nausea. If you do experience any of the above, consult your physician before continuing any exercise.
- Always keep children and animals away from the rowing equipment. It is intended for adult use only.
- Place the equipment on a solid, flat level surface, ideally with a protective cover, to protect your flooring. Always ensure there is a minimum of two feet or 60cm of space around the equipment.
- Ensure that all nuts and bolts are securely fastened before using the equipment.
- Regularly examine the equipment for any damage and/or wear and tear to maintain the overall safety conditions.

- If you find any defective components while assembling the equipment, or you hear any unusual noises coming from the equipment during exercise, cease using the equipment immediately. Do not continue using the equipment until the problem has been rectified.
- Wear suitable workout clothing when using the equipment. Avoid wearing loose clothing that may get caught.
- Do not place fingers or small objects into the moving parts of the equipment. The maximum weight capacity of this unit is 150kg.
- Move the equipment with consideration and care for yourself and others around you. Seek assistance if necessary.
- Do not place the equipment within any extreme temperatures or conditions, including damp areas, which may lead to corrosion and operational issues.
- This equipment is designed for indoor and home use only. It is not intended for commercial use.

**⚠ WARNING: IF YOU ARE OVER THE AGE OF 45 OR HAVE PRE-EXISTING HEALTH CONDITIONS, PLEASE CONSULT YOUR PHYSICIAN BEFORE USING THE EQUIPMENT.**

**BLUEFIN FITNESS ASSUMES NO RESPONSIBILITY FOR PERSONAL INJURY OR PROPERTY DAMAGE SUSTAINED BY OR THROUGH THE USE OF THIS PRODUCT.**

## HARDWARE PARTS LIST

**i** BEFORE INSTALLING THE BLADE AQUA M-1, ENSURE THAT ALL OF THE FOLLOWING PARTS ARE INCLUDED:

NB. SOME SMALLER COMPONENTS MAY ALREADY BE PRE-FITTED TO LARGER COMPONENTS TO ASSIST WITH INSTALLATION.



19 **x1**



20 **x1**



80 M8 **x1**



59 M8\*15 **x4**



61 M4\*12 **x2**



62 M8\*15 **x4**



68 M8\*15 **x8**



72 M6\*10 **x2**

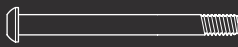

66 M8\*65 **x4**



74 OD20\*ID8.5\*1.5 **x8**



40 **x1**



93 S5 **x1**



94 S13-17 **x1**

## PRE-ASSEMBLY CHECKLIST

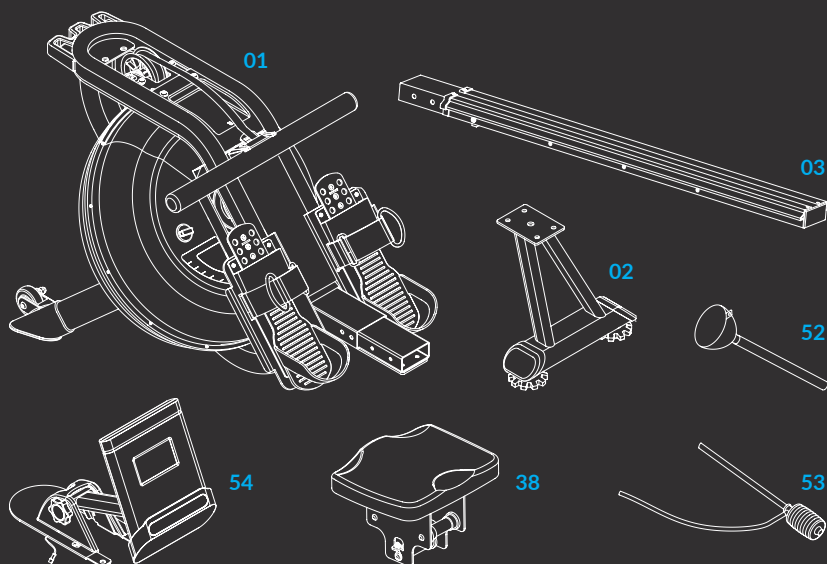

PART	DESCRIPTION	QUANTITY
01	Main Frame	x1
02	Rear Stabiliser	x1
03	Slide Rail	x1
38	Seat	x1
52	Funnel	x1
53	Pumping Siphon	x1
54	Computer	x1

# 01

## ASSEMBLY INSTRUCTIONS

**ⓘ NOTE: WE RECOMMEND HAVING TWO PEOPLE TO ASSEMBLE THE EQUIPMENT**

- Slide the **Seat 38** onto the **Slide Rail 03**.
- Secure the **Limit Pad 40** with **x2 Flat Cross Screws 72**.
- Attach the **Rear Stabiliser 02** to the **Slide Rail 03** with **x4 Washers 74** and **x4 Outer Hex Screws 59**.
- Tighten with **Spanner 94**.



**72** M6\*10 **x2**



**59** M8\*15 **x4**



**94** S13-17 **x1**



**74** OD20\*ID8.5\*1.5 **x4**

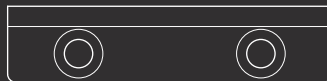

**40** **x1**

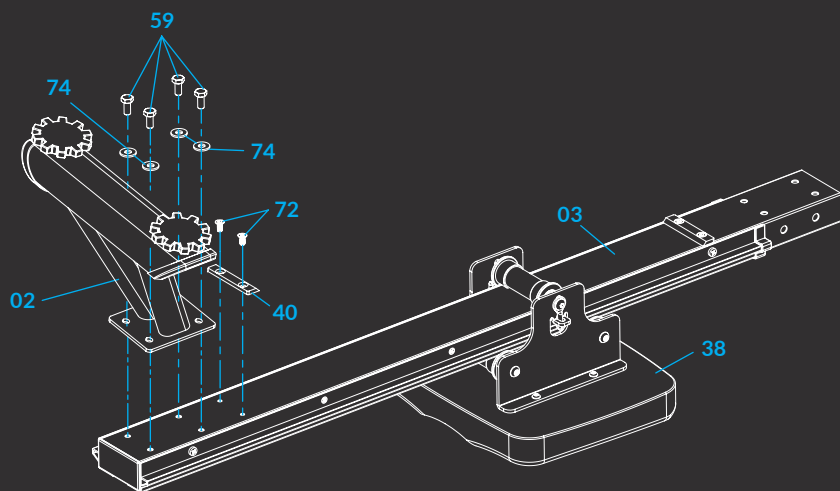

# 02

## ASSEMBLY INSTRUCTIONS

- Secure the Left/Right Decorative for Rail 19 and 20 with x2 Cross Screw 61 onto the Slide Rail 03. Tighten with Spanner 94.



19 x1



20 x1



61 M4\*12 x2



94 S13-17 x1

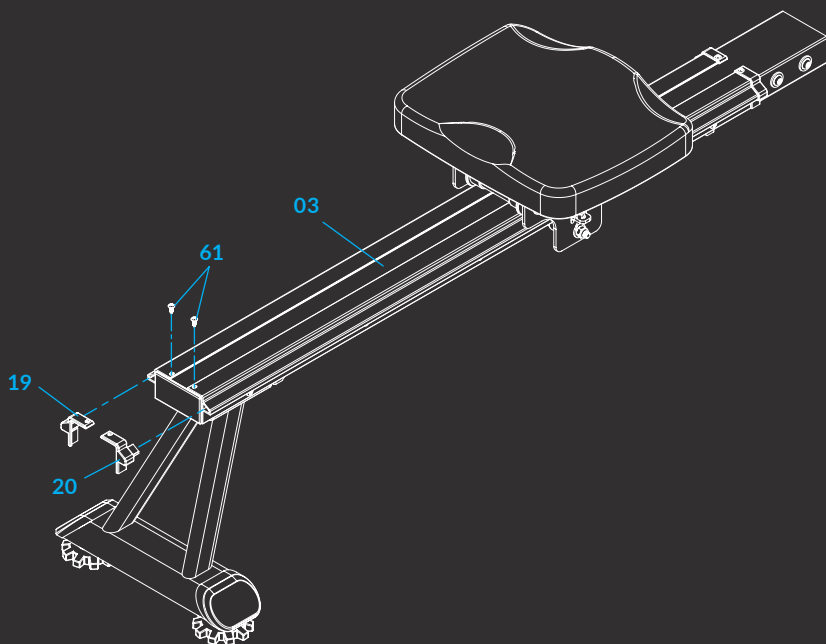

# 03

## ASSEMBLY INSTRUCTIONS

① MOVE THE SEAT 38 TO THE FRONT OF THE SLIDE RAIL 03 BEFORE ASSEMBLY TO PREVENT IT FROM MOVING DURING ASSEMBLY.

- Attach the Slide Rail 03 to the Main Frame 01 by using x4 Washers 74 x4 Screws 68 and x4 Flat Screws 62.
- Insert all 8 screws partially into the holes first, and then tighten with Allen Wrench 93.



62 M8\*15 **x4**



68 M8\*15 **x4**



74 OD20\*ID8.5\*1.5 **x4**



93 S5 **x1**

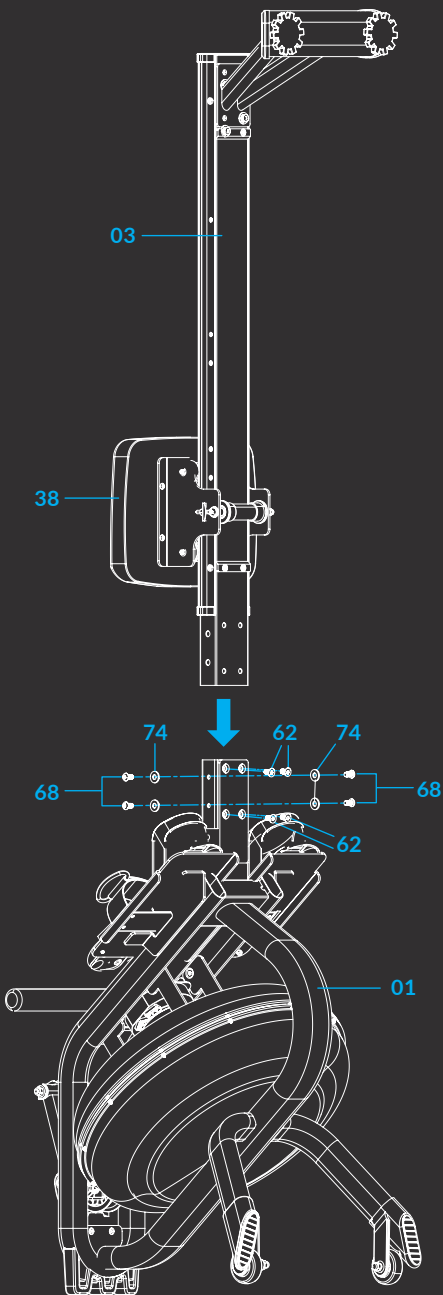

# 04

## ASSEMBLY INSTRUCTIONS

- Attach the support for Console 54 to Main Frame 1, ensuring the wires are connected. Then tighten with x4 Screws 68 and Allen Wrench 93.



66 M8\*65 x4



80 M8 x1



94 S13-17 x1



93 S5 x1



74 OD20\*ID8.5\*1.5 x2

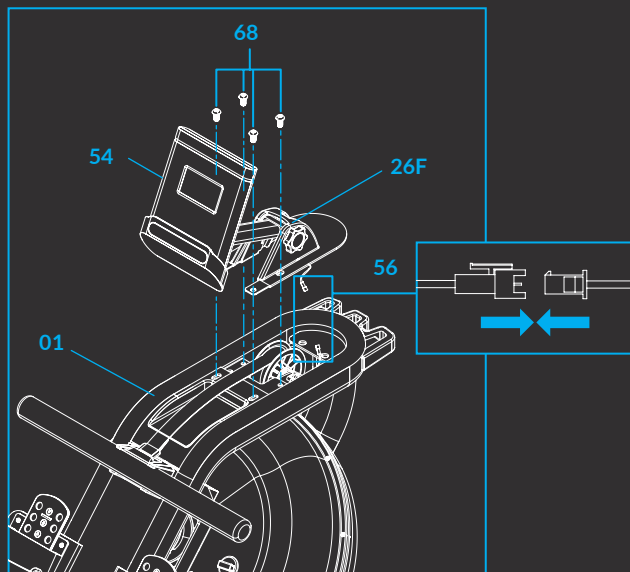

Unlock



Lock

To release turn anticlockwise 3 times, adjust the **Console 54** angle then turn clockwise to lock.

# 05

## WATER TANK

NEVER USE POOL CHLORINE OR CHLORINE BLEACH TO FILL THE WATER TANK AS THIS WILL DAMAGE THE TANK AND VOID THE WARRANTY.

ADD 1X WATER PURIFICATION TABLET EVERY 2-3 MONTHS, OR AS NEEDED. IF THE WATER TURNS CLOUDY, REPLACE THE WATER IN THE TANK.

DO NOT CONSUME THE WATER FROM THE TANK. ALWAYS REMOVE WATER FROM THE TANK BY USING THE SIPHON PUMP AND DISPOSE OF IT SAFELY.

### FILLING AND EMPTYING

- Remove **Fill Plug 50** from the **Upper Tank Cover 24**.
- To fill the tank with water, refer to **Fig. A**.  
Insert the **Funnel 52** into the tank, then use a cup or the **Siphon Pump 53** and a bucket to fill the tank. Use the water level gauge on the side of the tank to measure desired water level.
- To empty the tank, refer to **Fig. B**.  
Place a bucket next to the rower, and use the **Siphon Pump 53** to pump out the water from the tank into the bucket.
- Insert the **Fill Plug 50** into the **Upper Tank Cover 24**.  
Wipe excess water off the frame.

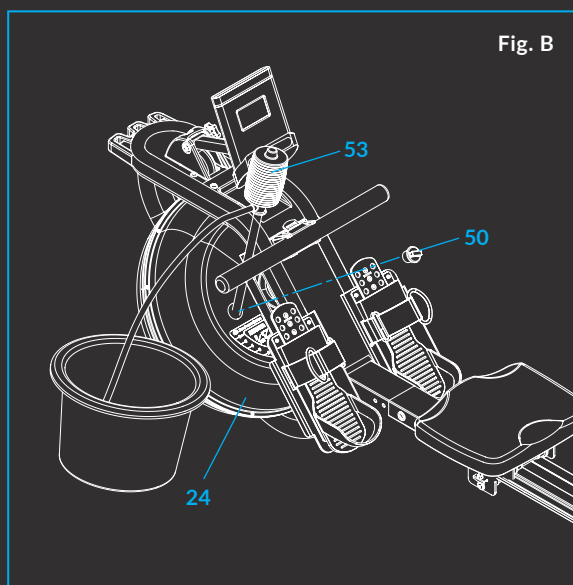
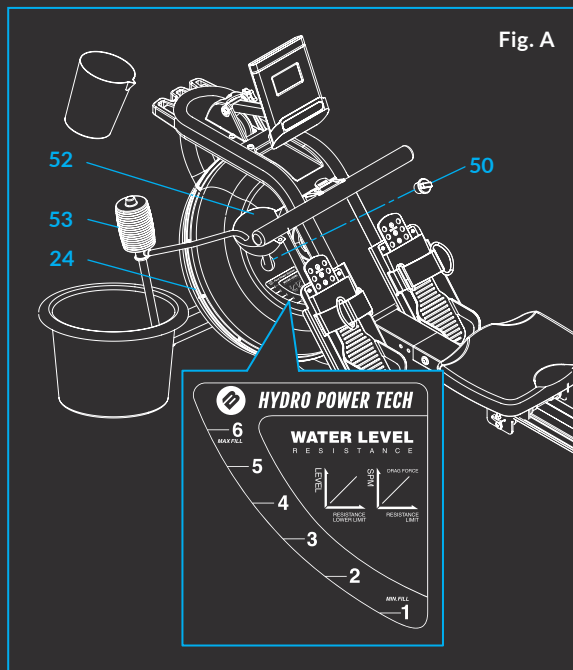

## WATER TANK

### CARE AND MAINTENANCE

- Water purification tablets help maintain the condition of the water for continued use.
- You should use distilled water to fill your tank.
- Once you insert the water purification tablet into the water tank, commence rowing to stir the tablet, ensuring that it is dissolved within the water.
- Each water purification tablet contains around 167mg of sodium dichloroisocyanurate. Please avoid any contact with metal objects to avoid any corrosion or rust occurring.

 **WATER PURIFICATION TABLETS AREN'T INCLUDED WITH THE PRODUCT DUE TO RESTRICTIONS ON INTERNATIONAL SHIPPING. PLEASE PURCHASE WATER PURIFICATION TABLETS SEPARATELY FROM A RELIABLE LOCAL VENDOR OR ONLINE RETAILER.**



# 06

## MOVING YOUR BLADE AQUA

- To move the rower, lift up the **Rear Stabilizer 02** until the **Moving Wheels 18** on the front stabiliser touches the ground.
- With the wheels on the ground, gently wheel and transport the rower to your desired location with ease.

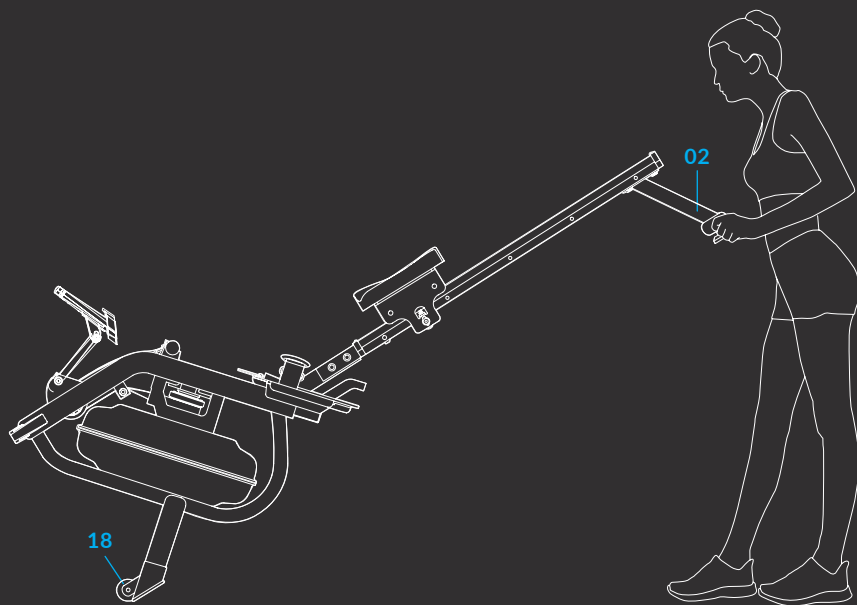

## STABILISING YOUR BLADE AQUA

 CAUTION! KEEP HANDS CLEAR OF THE SLIDING SIDE RAILS WHEN ADJUSTING YOUR BLADE AQUA AS THE MOVEMENT OF THE SEAT MAY CAUSE INJURY.

- Should the machine ever feel imbalanced during use, adjust the **Adjust Knob 23** below the **Rear Stabilizer 02** of the machine to stabilize the rower.

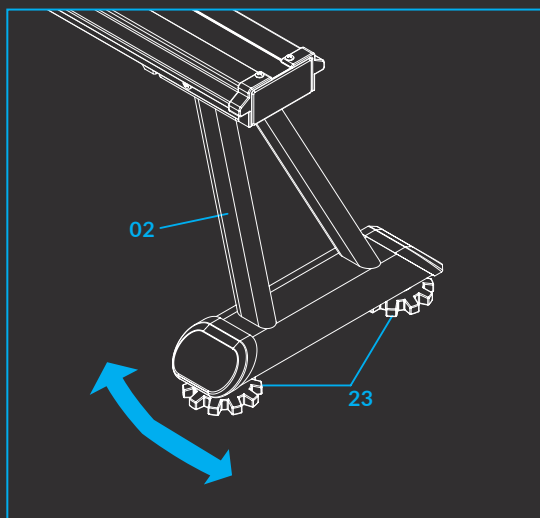

## STORING YOUR BLADE AQUA

⚠ NB. ENSURE THAT YOU MOVE THE SEAT 38 TO THE FRONT OF THE SIDE RAIL 3 WHEN RAISING THE ROWER UPWARDS SO THAT THE SEAT DOESN'T MOVE DURING TRANSPORT.

⚠ CAREFULLY FOLD THE SIDE RAIL UP, ENSURING THAT YOU AND ANYONE AROUND YOU WILL NOT BE AFFECTED.

- When not in use, save space by storing the rower away in a vertical position. To do so, lift the **Rear Stabilizer 02** and raise the rower upwards.
- If you're not planning on using the rower for over one month, empty the tank before storing away.

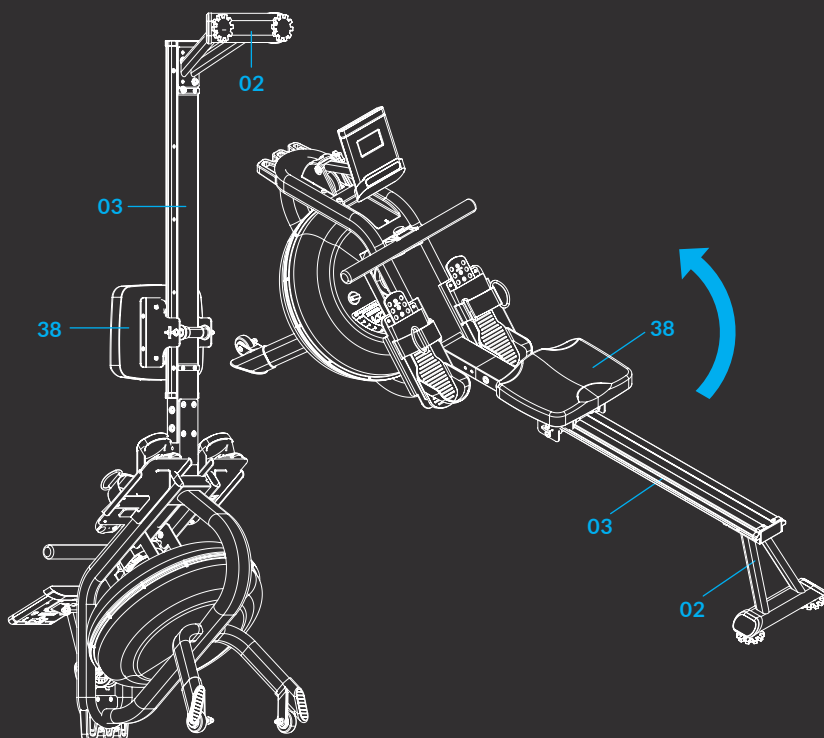



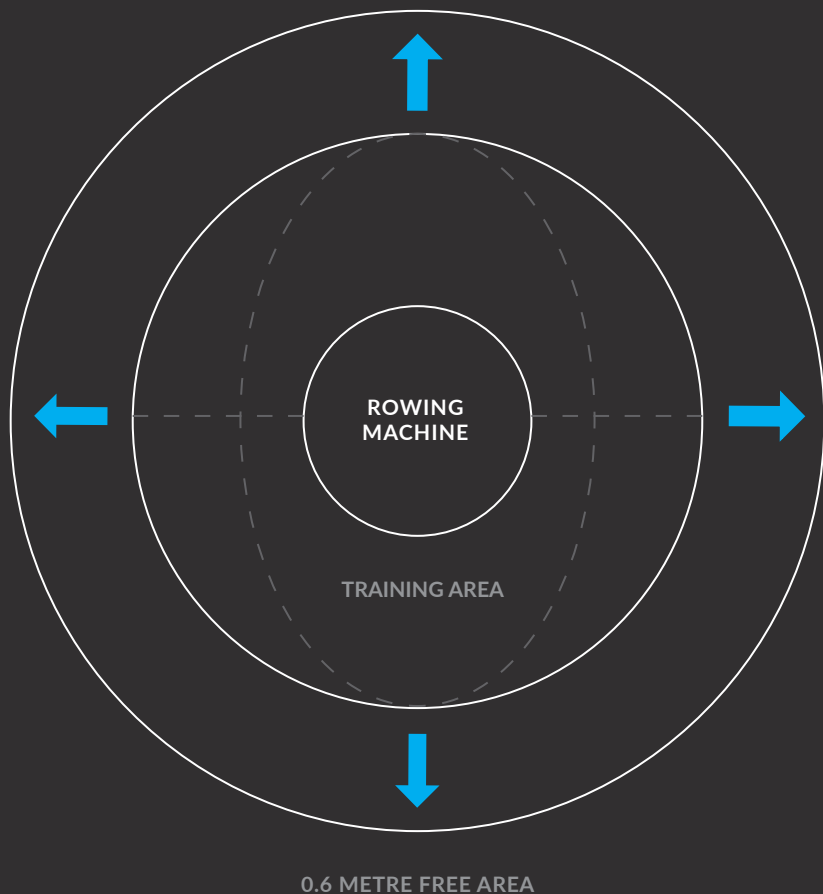

# CONSOLE FUNCTIONS

## FUNCTION BUTTONS

<b>MODE</b>	Push down to select functions. Push down to reset Time/Count/Distance and Calories for 2 seconds.
<b>SET</b>	To set the values of Time/Count/Distance/Calories and Pulse when not in scan mode.
<b>RESET</b>	Push down to reset Time/Count/Distance/Calories and Pulse.

## FUNCTIONS AND OPERATIONS

Press the **MODE** button, select **TIME**, at which point the word **SCAN** will appear on the left-hand side of the monitor. From here all 6 functions will appear on the display for 6 seconds each: **TIME**, **COUNT**, **DISTANCE**, **CALORIE**, **RPM** and **PULSE**.

When your desired function appears on the screen, press the **MODE** button to choose this function and select the parameters you want to measure during your workout.

<b>TIME</b>	Displays how long you have been exercising.
<b>COUNT</b>	Displays the amount of rowing strokes you are achieving.
<b>DISTANCE</b>	Displays the distance of exercise covered from start to end.
<b>CALORIES</b>	Displays the number of calories burned during the exercise.
<b>RPM</b>	Displays the number of rowing strokes you are achieving per minute.
<b>PULSE</b>	Displays your current heart rate during the exercise. <i>The wireless heartbeat chest belt can also be worn for a more accurate heart rate measurement.</i>

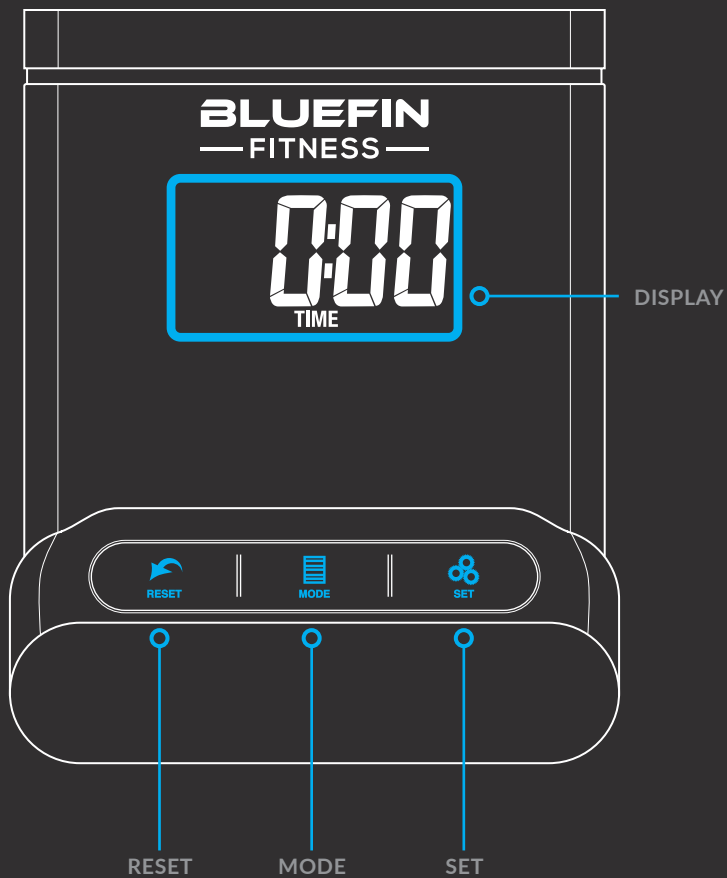

# CONSOLE OPERATION

## TARGET TRAINING SETTINGS

This console has five target training modes: Time, Count, Distance, Calories and Pulse. Once you have chosen your training mode, press the MODE button to remove the SCAN flashing on the display.

**TIME** Press the MODE button, choose TIME, and press the SET button to set how long you want to exercise for. You can press and hold the set button to speed up the setting. When you have reached your required time, release the button. Once you start working out on the rower the timer will start and count down from the time duration set. Once the training goal has been completed the console will beep, signalling the end of your training. If you continue to train from this point the display will automatically begin to count up from zero.

**COUNT** Press the MODE button, choose COUNT, and press the SET button to set the number of full rowing strokes you want to achieve. You can press and hold the set button to speed up the setting. When you have reached your required count, release the button. Once you start working out on the rower the display will begin counting down from the target set. Once the training goal has been completed the console will beep, signalling the end of your training. If you continue to train from this point the display will automatically begin to count up from zero.

**DISTANCE** Press the MODE button, choose DISTANCE, and press the SET button to set the virtual distance you want to achieve. You can press and hold the set button to speed up the setting. When you have reached your required distance, release the button. Once you start working out on the rower the display will begin counting down from the target set. Once the training goal has been completed the console will beep, signalling the end of your training. If you continue to train from this point the display will automatically begin to count up from zero.

**CALORIES** Press the MODE button, choose CALORIES, and press the SET button to the number of calories you want to burn during your workout. You can press and hold the set button to speed up the setting. When you have reached your required calorie number, release the button. Once you start working out on the rower the display will begin counting down from

the target set. Once the training goal has been completed the console will beep, signalling the end of your training. If you continue to train from this point the display will automatically begin to count up from zero.

**PULSE** Press the MODE button, choose PULSE, and press the SET button to set the target heart rate you want to achieve during your workout. You can press and hold the set button to speed up the setting. When you have reached your required heart rate number, release the button. Once you start working out on the rower the display will begin counting down from the target set. Once the training goal has been completed the console will beep, signalling the end of your training. If you continue to train from this point the display will automatically begin to count up from zero.

You can always change the training targets set by pressing the RESET button to clear all current settings. You can then choose your training targets again with the above instructions.

**NB. IF THE DISPLAY IS FAINT OR SHOWS NO FIGURES, PLEASE REPLACE THE DISPLAY BATTERIES.**

**THE CONSOLE WILL AUTOMATICALLY TURN OFF IF THERE IS NO SIGNAL RECEIVED AFTER 4 MINUTES.**

**THE MONITOR WILL AUTOMATICALLY TURN ON WHEN YOU BEGIN USING THE ROWER.**

**THE MONITOR WILL AUTOMATICALLY START TO CALCULATE YOUR TRAINING AS SOON AS YOU START ROWING, AND UP TO 4 SECONDS AFTER YOU FINISH.**

FUNCTION	SCAN	Every 6 seconds
	TIME	0:00~99:59
	COUNT	0~9999 TIMES
	DISTANCE	0~9999 METRES
	CALORIES	0.0~999.9 CAL
	RPM	0~999 TIMES/MIN
	PULSE	40~220 BPM

BATTERY TYPE	2pcs of SIZE -AA orUM -3
OPERATING TEMPERATURE	0°C~ +40°C
STORAGE TEMPERATURE	-10°C~ +60°C

## KINOMAP FITNESS APP

### ADDING THE APP

- Search for KINOMAP on your smartphone's app store and download.
- After the download is complete, open the KINOMAP app and register your personal details.
- Turn Bluetooth on and ensure that the Blade Aqua console is powered on and in the wake-up state.
- Sync your Blade Aqua to the KINOMAP app as follows:



## 01

Press MORE to bring up the Equipment page, select **Equipment Management**.

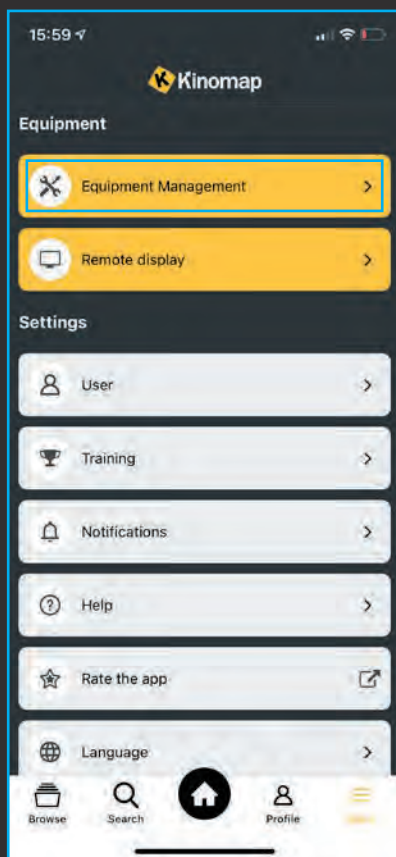

## 02

Press the + icon.

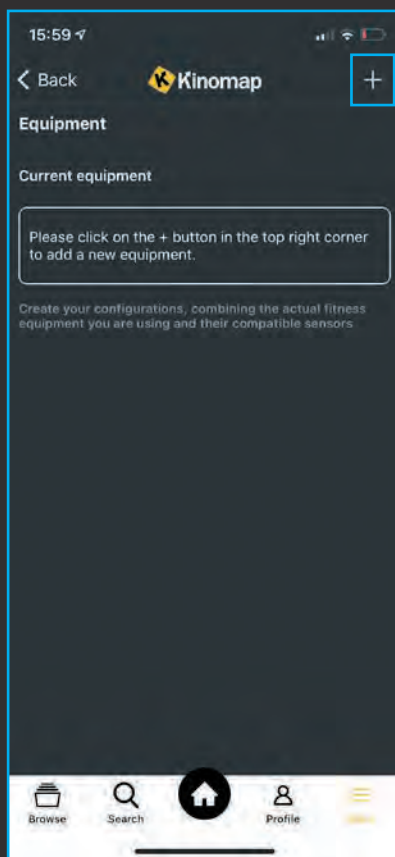

# 03

Select the **Rowing** icon.

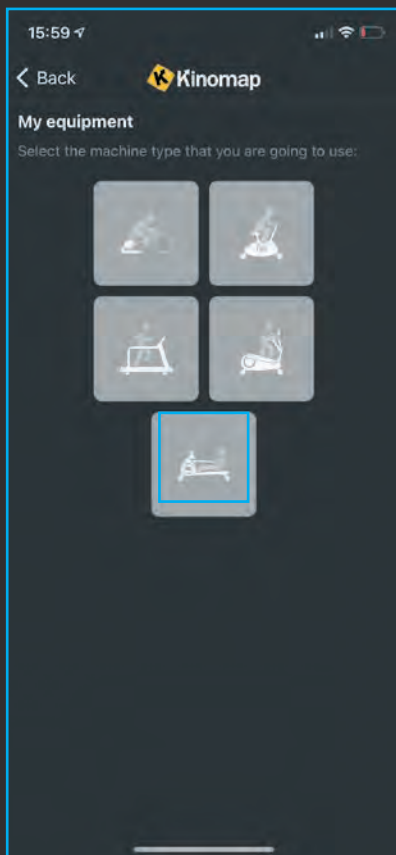

# 04

Select the **Bluefin Fitness** icon.

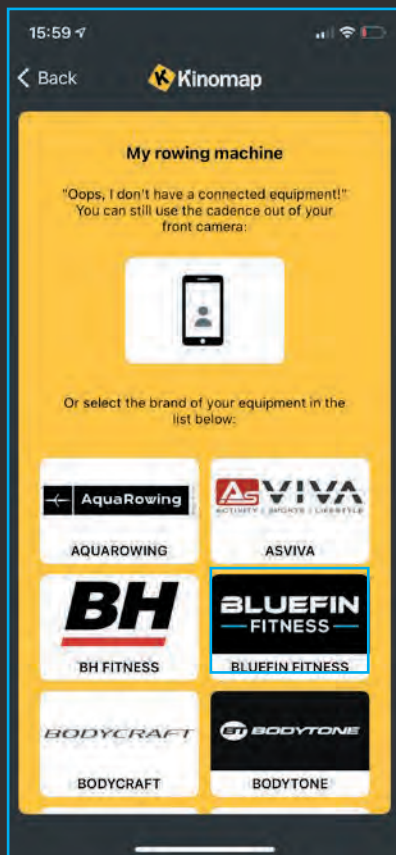

## 05

Select **Blade Aqua M-1**.

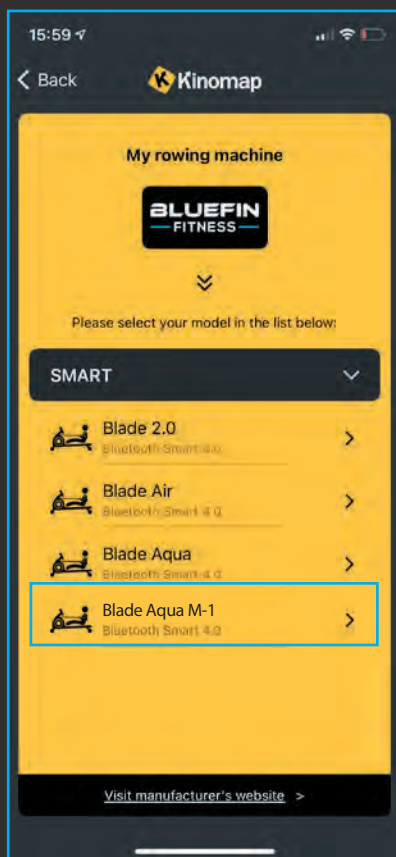

## 06

Add your **Blade Aqua M-1** to complete, start your exercise.

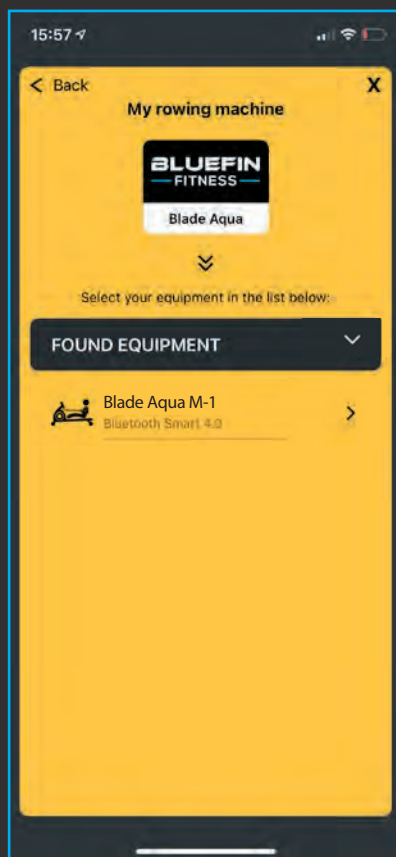

## WARM UP AND COOL DOWN

TO PREVENT INJURIES, YOU SHOULD ALWAYS WARM-UP AND COOL-DOWN WITH VARIOUS STRETCHES BEFORE AND AFTER EACH WORKOUT.

WE RECOMMEND THE FOLLOWING STRETCHES, WHICH WILL REDUCE THE RISK OF ANY MUSCLE INJURY OR SPASM DURING EXERCISE. NEVER OVERSTRETCH OR PULL YOUR MUSCLES.

### SIDE BENDS

Pass one arm up and over your head, bending your upper body in the same direction. Hold this position for 10 to 15 seconds and slowly straighten yourself back up. Repeat this 3 times for each side.

### TOE TOUCH

Slowly bend forward from your waist, letting your back and shoulders relax as you stretch towards your toes. Reach down as far as you can go and hold for 15 seconds. Then relax and repeat 3 times.

### CALF-ACHILLES STRETCH

Lean against a wall with your left leg in front of the right and your arms on the wall. Keep your right leg straight and your left foot on the floor, bend the left leg and lean forward by moving your hips toward the wall. Hold, then repeat on the other leg for 15 seconds. Repeat 3 times for each leg.

### QUADRICEPS STRETCH

With one hand against a wall for balance, reach behind you and pull your right foot up. Bring your heel as close to your buttocks. Hold for 10-15 seconds. Repeat three times for each foot.

### INNER THIGH STRETCH

Sit with the soles of your feet together and your knees pointing outwards. Pull your feet as close to your groin as possible. Gently push your knees towards the floor. Hold for 15 seconds. Then relax and repeat 3 times.

# ROWING EXERCISES

## USING YOUR ROWING MACHINE REGULARLY WILL:

- Improve your overall physical fitness, strengthening the heart and improving circulation as well as exercising all the major muscle groups: the back, waist, arms, shoulders, hips and legs.
- Tone your muscles & in conjunction with a calorie-controlled diet: it will help you lose weight. Rowing is an extremely effective form of exercise.

## THE BASIC ROWING STROKE

- Sit on the saddle and fasten your feet to the pedals using the straps. Then take hold of the rowing bar.
- Take up the starting position, leaning forward with your arms straight and knees bent as shown in **Fig 1**.
- Push yourself backwards, straightening your back and legs at the same time **Fig 2**.
- Continue this movement until you are leaning slightly backwards, during this stage you should bring your arms out of the side **Fig 3**. Then return to stage 2 and repeat.

## TRAINING

- Rowing is a strenuous form of exercise, so it's best to start training with low resistance and for short periods if you are a beginner. As you progress, you can increase the resistance and training time to suit your needs and fitness goals.

We recommend you begin training on alternate days, approx. 3 times a week to give your body time to recover between workouts.

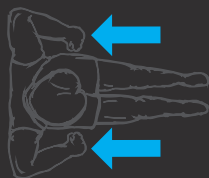

Fig 1



Fig 2



Fig 3

# ROWING EXERCISES

## ALTERNATE ROWING STYLES

### ARMS ONLY ROWING

This rowing style will tone the muscles in your arms, shoulders, back and stomach. Sit as shown in **Fig 4** with your legs straight, lean forward and grasp the handles. In a gradual and controlled manner lean back to just past the upright position continuing to pull the handles towards your chest. Return to the starting position and repeat.

### LEGS ONLY ROWING

This exercise will tone the muscles in your legs and back. With your back straight and arms stretched out, bend your legs until you are grasping the rowing arm handles in the starting position, **Fig 7**. Use your legs to push your body back whilst keeping your arms and back straight.

### MUSCLE TONING

The most effective way to tone your muscles while rowing is to set a high resistance while being mindful not to cause any injury by over-exerting your muscles. We recommend always warming up and cooling down at a light resistance and choosing to increase your resistance in the final part of your training when your muscles have warmed up properly.

### WEIGHT LOSS

The more effort you put into your rowing workouts, the more calories you will burn. Look to gradually increase the resistance, duration and effort you put into each workout, as these factors will assist you in losing weight.



Fig 4



Fig 5



Fig 6



Fig 7



Fig 8



Fig 9

## MANUFACTURER WARRANTY

🔒 THE BLUEFIN WARRANTY COVERS ANY TECHNICAL FAULTS WITH YOUR ITEM. IF YOU NEED TO MAKE A WARRANTY CLAIM CONTACT US VIA EMAIL AT: [SUPPORT@BLUEFINTRADING.CO.UK](mailto:SUPPORT@BLUEFINTRADING.CO.UK)

### YOUR WARRANTY DOES NOT COVER THE FOLLOWING:

- General wear and marks from use.
- Water damage.
- Damage due to improper use.
- Chassis damage & scratching due to improper use or dropping.
- Electronic damage due to improper use or dropping.
- Your warranty begins on receipt of delivery.
- Technical faults are covered for 12 months.

If you have any questions regarding your warranty please email us at: [support@bluefintrading.co.uk](mailto:support@bluefintrading.co.uk)



William Vaughan, CEO  
Bluefin Trading Ltd.

## EU DECLARATION OF CONFORMITY

For the latest & up-to-date EU declaration of conformity for this product, please visit: [www.bluefinfitness.com/manuals/bladeaqua\\_m1\\_DoC.pdf](http://www.bluefinfitness.com/manuals/bladeaqua_m1_DoC.pdf)

Importer Address:  
Bluefin Trading Ltd  
Keelham Farm  
Hebden Bridge  
UK  
HX7 8TG  
[www.bluefinfitness.com](http://www.bluefinfitness.com)



### WASTE ELECTRICAL AND ELECTRONIC EQUIPMENT

Do not dispose of this device with domestic waste. The components of the device must be separately recycled or disposed of according to local regulations. The system operator may also return any waste electrical and electronic equipment to the manufacturer at the end of their lifetime. Charges incurred for transport to the manufacturer will be at the expense of the owner of the waste electrical and electronic equipment.



### BATTERY DIRECTIVE

Do not dispose of any batteries with domestic waste. Please recycle or safely dispose of batteries in accordance with local regulations. Any batteries supplied by the manufacturer or distributor can be returned at the end of their lifetime for recycling and safe disposal. Charges incurred for transport to the manufacturer or distributor will be at the expense of the owner of the batteries.



### RECYCLING OF PACKAGING MATERIALS

Do not dispose of packaging with domestic waste. All packaging materials can be safely recycled according to local regulations.

# BLADE AQUA



M-1 WATER RESISTANCE ROWER

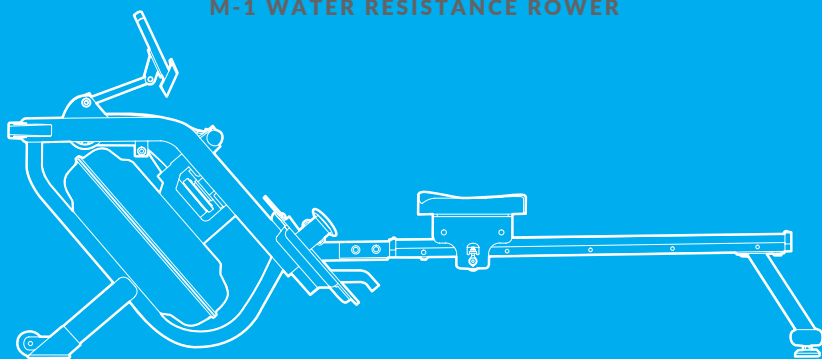



## BENVENUTO NELLA COMMUNITY BLUEFIN FITNESS

GENTILE CLIENTE,

GRAZIE PER AVER SCELTO IL VOGATORE BLUEFIN FITNESS BLADE AQUA M-1. PER OTTENERE SEMPRE IL MASSIMO DAL TUO NUOVO VOGATORE ASSICURATI CHE TUTTE LE PERSONE CHE UTILIZZANO L'ATTREZZATURA LEGGANO E COMPRENDANO ATTENTAMENTE IL SEGUENTE MANUALE PRIMA DELL'USO.

BLUEFIN FITNESS NON SI ASSUME ALCUNA RESPONSABILITÀ PER DANNI CAUSATI DA UN USO IMPROPRIO O NON CORRETTO DELL'ATTREZZO.

CI AUGURIAMO CHE TI PIACCIA USARE IL TUO NUOVO VOGATORE BLADE AQUA M-1. SE SEI INTERESSATO A ESSERE SEMPRE AGGIORNATO SULLA NOSTRA GAMMA DI ATTREZZATURE PER IL FITNESS, DAI UN'OCCHIATA AL NOSTRO SITO WEB: [BLUEFINFITNESS.COM](https://www.bluefinfitness.com) E SEGUICI SUI NOSTRI SOCIAL:

**FACEBOOK** [FACEBOOK.COM/BLUEFINFITNESS](https://www.facebook.com/bluefinfitness)

**INSTAGRAM** [@BLUEFINFITNESS](https://www.instagram.com/bluefinfitness)

**TWITTER** [@BLUEFIN\\_FITNESS](https://twitter.com/bluefin_fitness)

**LINKEDIN** [LINKEDIN.COM/BLUEFIN-FITNESS](https://www.linkedin.com/company/bluefin-fitness)

IL TEAM DI BLUEFIN FITNESS

## MISURE DI SICUREZZA

**i** COME PRECEDENTEMENTE SCRITTO, SI PREGA DI ASSICURARSI CHE TUTTE LE PERSONE CHE UTILIZZANO BLADE AQUA M-1 ABBIANO LETTO E COMPRESO QUESTO MANUALE PRIMA DELL'USO.

**SI CONSIGLIA DI CONSERVARE QUESTO MANUALE ANCHE PER FUTURE LETTURE.**

**Informazioni generali sulla sicurezza che devono essere sempre osservate quando si utilizza Blade Aqua M-1.**

- Consulta sempre il tuo medico prima di iniziare qualsiasi programma di esercizi, specificando eventuali condizioni mediche o fisiche che potrebbero mettere a rischio la tua salute e sicurezza. Questo, soprattutto, se stai assumendo farmaci per il cuore, la pressione sanguigna o il colesterolo.
- Interrompi immediatamente l'esercizio se si verifica uno dei seguenti sintomi durante l'esercizio: dolore acuto, senso di oppressione al petto, battito cardiaco irregolare, mancanza di respiro, vertigini, nausea. Se si verifica una delle situazioni sopra descritte consulta immediatamente il tuo medico prima di continuare qualsiasi esercizio.
- Tieni sempre bambini e animali lontani dall'attrezzatura. Il vogatore è destinato esclusivamente all'uso da parte di persone adulte.
- Posiziona l'attrezzatura su una superficie piana e solida, meglio coprire il pavimento per non rischiare di rovinarlo. Assicurati sempre che ci siano almeno 60 cm di spazio intorno all'attrezzo.
- Assicurati che tutti i dadi e i bulloni del vogatore siano fissati saldamente prima dell'utilizzo.
- Esamina regolarmente l'attrezzatura per eventuali danni e/o usura, così da mantenere sempre le condizioni generali di sicurezza.

- Se riscontri componenti difettosi durante l'assemblaggio dell'attrezzatura o senti rumori insoliti durante l'esercizio interrompi immediatamente l'utilizzo del vogatore. Non continuare a utilizzare l'attrezzo finché il problema non è stato risolto.
- Quando utilizzi il vogatore indossa indumenti da allenamento adeguati. Evita di indossare abiti larghi che potrebbero impigliarsi.
- Non inserire dita o piccoli oggetti nelle parti mobili dell'attrezzo.
- Il peso massimo sopportato da questo vogatore è di 150 kg.
- Sposta l'attrezzatura con attenzione per te stesso e per gli altri intorno a te. Chiedi aiuto a qualcuno se necessario.
- Non posizionare l'attrezzo a temperature o condizioni estreme, comprese le aree umide, che potrebbero causare corrosione e problemi durante l'uso.
- Questa apparecchiatura è progettata esclusivamente per uso interno e domestico. Non è destinato all'uso professionale o commerciale.

**⚠ ATTENZIONE: SE HAI OLTRE 45 ANNI O HAI PROBLEMI DI SALUTE PRE-ESISTENTI, CONSULTA IL TUO MEDICO PRIMA DI UTILIZZARE IL VOGATORE.**

**BLUEFIN FITNESS NON SI ASSUME ALCUNA RESPONSABILITÀ PER LESIONI PERSONALI O DANNI MATERIALI CAUSATI DA O ATTRAVERSO L'USO DI QUESTO PRODOTTO.**

## ELENCO COMPONENTI

**i** PRIMA DI INIZIARE IL MONTAGGIO DI BLADE AQUA M-1 ASSICURATI CHE TUTTI I SEGUENTI COMPONENTI SIANO INCLUSI:

**NB:** ALCUNI COMPONENTI PIÙ PICCOLI POSSONO GIÀ ESSERE PREMONTATI A COMPONENTI PIÙ GRANDI PER FACILITARE IL MONTAGGIO..



**19 x1**



**20 x1**



**80 M8 x1**



**59 M8\*15 x4**



**61 M4\*12 x2**



**62 M8\*15 x4**



**68 M8\*15 x8**



**72 M6\*10 x2**



**66 M8\*65 x4**



**74 OD20\*ID8.5\*1.5 x8**

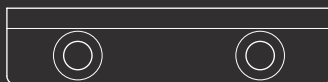

**40 x1**



**93 S5 x1**



**94 S13-17 x1**

## LISTA DI CONTROLLO PRE-MONTAGGIO

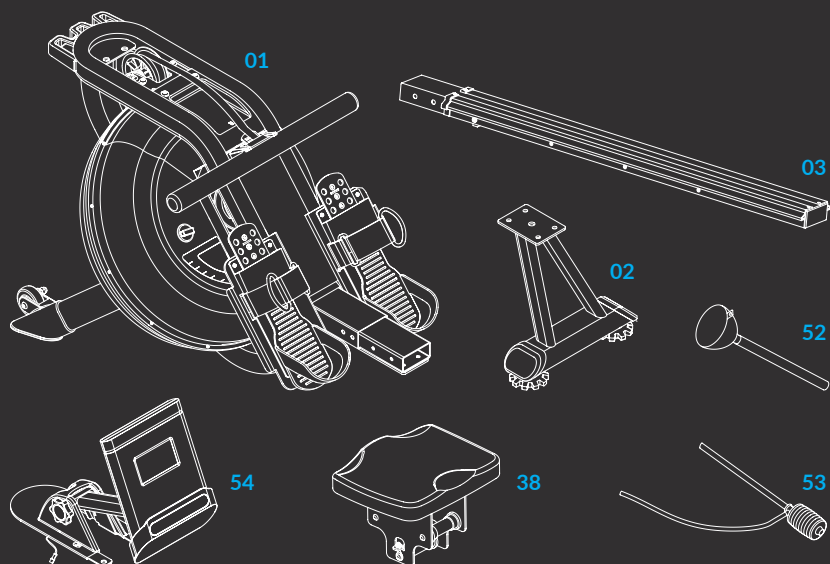

COMPONENTE	DESCRIZIONE	QUANTITÀ
01	Telaio principale	x1
02	Stabilizzatore posteriore	x1
03	Guida di scorrimento	x1
38	Sedile	x1
52	Imbuto	x1
53	Sifone di pompaggio	x1
54	Computer	x1

# 01

## ISTRUZIONI PER IL MONTAGGIO

**ⓘ** NOTA: SI CONSIGLIA DI ESSERE IN DUE PERSONE PER ASSEMBLARE L'ATTREZZATURA

- Fai scorrere il **Sedile 38** sulla **Guida di Scorrimento 03**.
- Fissa il **Blocco 40** con due viti a croce piatta **72**.
- Fissa lo **Stabilizzatore posteriore 02** alla **guida di scorrimento 03** con **quattro rondelle 74** e **quattro viti esagonali 59**.
- Serra con la speciale **chiave 94**.



**72** M6\*10 **x2**



**59** M8\*15 **x4**



**94** S13-17 **x1**



**74** OD20\*ID8.5\*1.5 **x4**



**40** **x1**

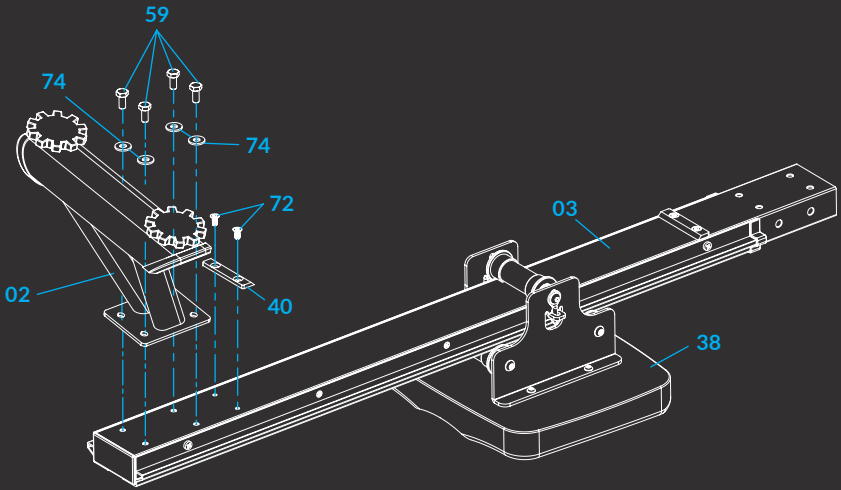

# 02

## ISTRUZIONI PER IL MONTAGGIO

- Fissa i perni **19** e **20** a sinistra e destra del binario di scorrimento **03** con due Viti a croce **61**. Serra con la chiave **94**.



**19 x1**



**20 x1**



**61 M4\*12 x2**

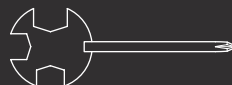

**94 S13-17 x1**

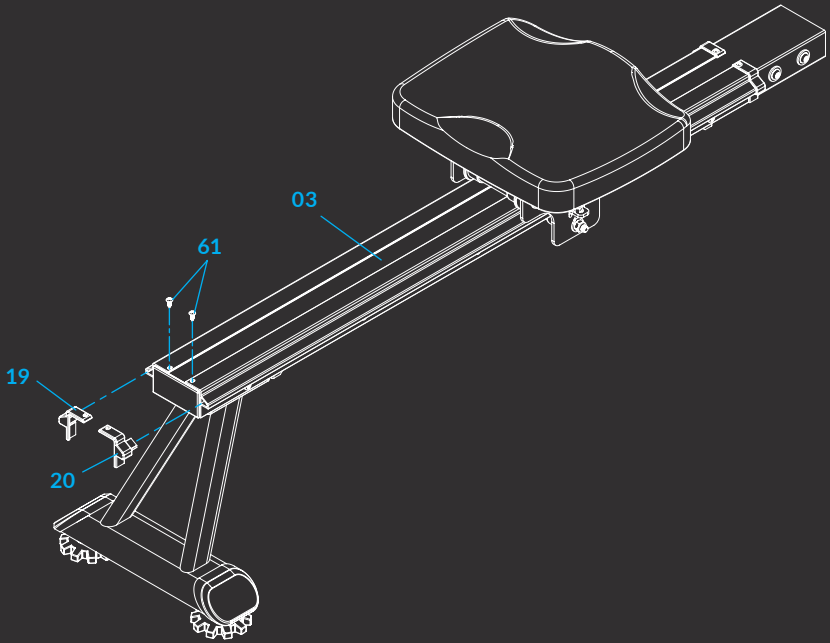

# 03

## ISTRUZIONI PER IL MONTAGGIO

① SPOSTA IL SEDILE 38 NELLA PARTE ANTERIORE DELLA BARRA 03 PRIMA DEL MONTAGGIO, PER EVITARE CHE SI MUOVA DURANTE L'ASSEMBLAGGIO.

- Fissa la guida scorrevole 03 al telaio principale 01 utilizzando quattro rondelle 74, quattro Viti 68 e quattro viti piatte 62.
- Prima di serrare le viti inseriscile tutte e otto nei fori, quindi chiudile con la chiave a brugola 93.



62 M8\*15 x4



68 M8\*15 x4



74 OD20\*ID8.5\*1.5 x4



93 S5 x1

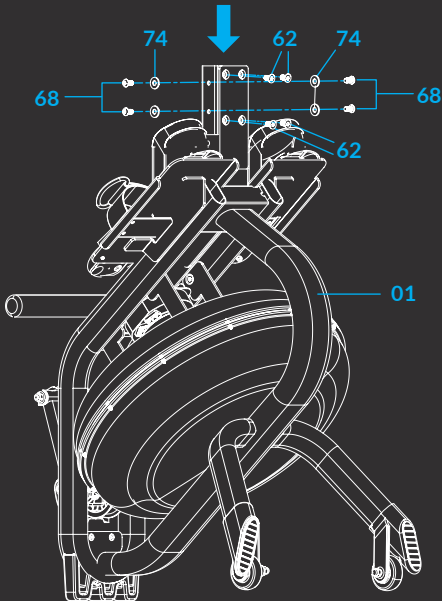
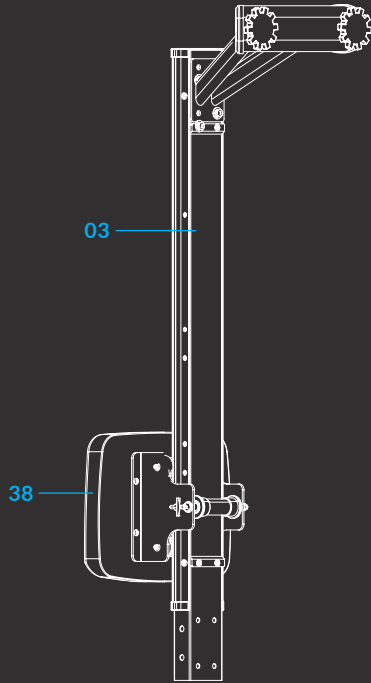

## ISTRUZIONI PER IL MONTAGGIO

- In secondo luogo, attacca il supporto per **Console 54** al **telaio principale 01**, assicurandoti che tutti i cavi siano collegati. Quindi serra con **quattro viti 66**, e chiave a **brugola 93**.



**66** M8\*65 **x4**



**80** M8 **x1**

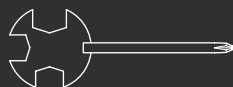

**94** S13-17 **x1**



**93** S5 **x1**



**74** OD20\*ID8.5\*1.5 **x2**

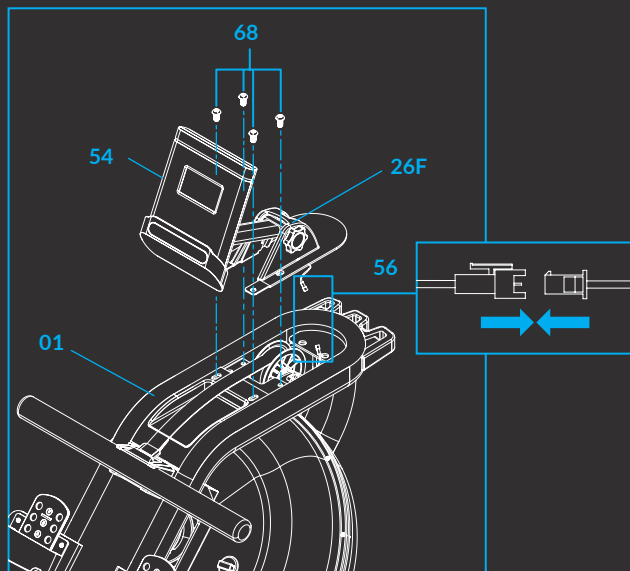

Sblocca



Blocca

Per sbloccare ruota tre volte in senso antiorario, regola l'angolo della Console 54 quindi ruota in senso orario per bloccare di nuovo.

# 05

## SERBATOIO DELL'ACQUA

NON UTILIZZARE MAI CLORO PER PISCINE O CANDEGGINA PER RIEMPIRE IL SERBATOIO DELL'ACQUA IN QUANTO LO DANNEGGEREBBE ANNULLANDO LA GARANZIA.

AGGIUNGI 1 COMPRESSA PER LA PURIFICAZIONE DELL'ACQUA OGNI 2-3 MESI O QUANDO NECESSARIO. SE L'ACQUA DIVENTA OPACA SOSTITUISCILA CON ACQUA PULITA.

NON CONSUMARE L'ACQUA DEL SERBATOIO. TOGLI SEMPRE L'ACQUA DAL SERBATOIO UTILIZZANDO LA POMPA A SIFONE E SMALTISCILA IN MODO SICURO E CORRETTO.

### RIEMPIMENTO E SVUOTAMENTO

- Rimuovi il **tappo 50** dal coperchio superiore del **serbatoio 24**.
- Per riempire d'acqua il serbatoio fai riferimento alla **Fig. A**. Inserisci l'**imbuto 52** nel serbatoio. Utilizza una tazza o la **pompa a sifone 53** e un secchio per riempire il serbatoio con acqua. Utilizza l'indicatore di livello dell'acqua che si trova sul lato del serbatoio per misurare il livello dell'acqua desiderato.
- Per svuotare il serbatoio fai riferimento alla **Fig. B**.
- Posiziona un secchio accanto al vogatore e usa la pompa a **sifone 53** per pompare fuori l'acqua dal serbatoio nel secchio.
- Inserisci il **tappo 50** nel coperchio superiore del **serbatoio 24**. Se necessario asciuga bene l'acqua in eccesso versatasi sul telaio.



## SERBATOIO DELL'ACQUA

### CURA E MANUTENZIONE

- Le pastiglie per la purificazione dell'acqua aiutano a mantenere l'acqua pulita per un uso continuato.
- E' consigliato usare acqua distillata per riempire il serbatoio.
- Una volta inserita la compressa per la purificazione dell'acqua nel serbatoio, inizia a remare per mescolare la compressa, assicurandoti che si sciolga completamente nell'acqua.
- Ogni compressa per la purificazione dell'acqua contiene circa 167 mg di dicloroisocianurato di sodio. Si prega di evitare qualsiasi contatto con oggetti metallici per evitare corrosione o ruggine.

**⚠ LE COMPRESSE PER LA PURIFICAZIONE DELL'ACQUA NON SONO INCLUSE CON IL PRODOTTO A CAUSA DI RESTRIZIONI SULLE SPEDIZIONI INTERNAZIONALI. SI PREGA DI ACQUISTARE LE COMPRESSE PER LA PURIFICAZIONE DELL'ACQUA SEPARATAMENTE DA UN FORNITORE LOCALE AFFIDABILE O DA UN RIVENDITORE ONLINE.**



## COME MUOVERE IL TUO BLADE AQUA M-1

- Per spostare il vogatore solleva il **supporto posteriore 02** fino a quando le **ruote mobili 18** sullo stabilizzatore anteriore toccano il suolo.
- Quando le ruote sono a terra ruota lentamente e trasporta il vogatore nella posizione desiderata.

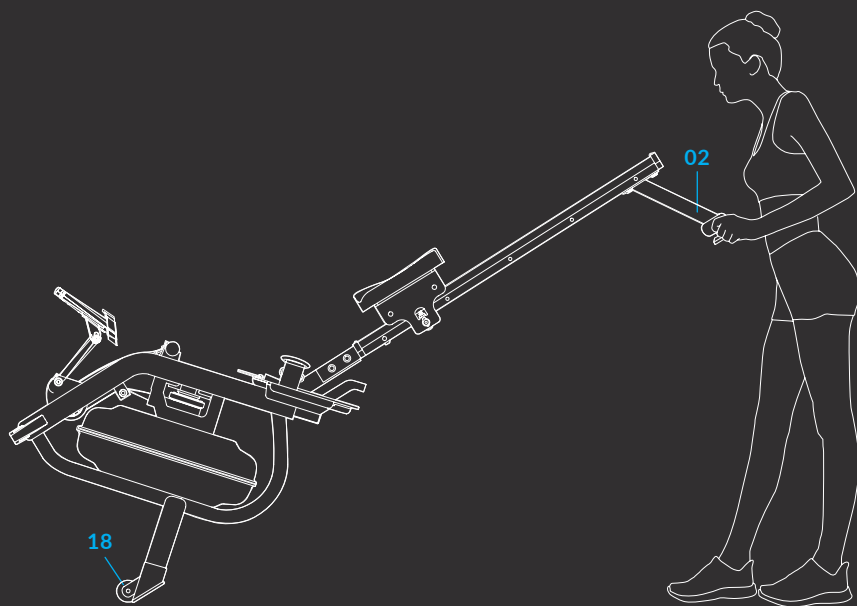

## STABILIZZARE IL TUO BLADE AQUA M-1

 **ATTENZIONE! TENERE LE MANI LONTANE DALLE SLITTE SCORREVOLI QUANDO SI REGOLA IL BLADE AQUA M-1 IN QUANTO IL MOVIMENTO DEL SEDILE PUÒ CAUSARE LESIONI.**

- Se la macchina dovesse risultare squilibrata durante l'uso ruota la manopola di **regolazione 23** sotto lo **stabilizzatore posteriore 02** della macchina per regolare la stabilità del vogatore.

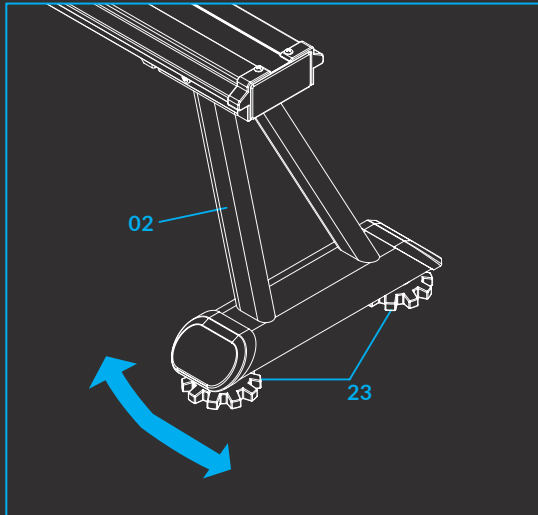

## RIPORRE E CONSERVARE IL TUO BLADE AQUA M-1

⚠ NB. ASSICURARTI DI SPOSTARE IL SEDILE 38 VERSO LA PARTE ANTERIORE DELLA BARRA LATERALE 3 QUANDO SI SOLLEVA IL VOGATORE VERSO L'ALTO IN MODO CHE IL SEDILE NON SI SPOSTI DURANTE IL TRASPORTO.

⚠ PIEGA CON ATTENZIONE LA SLITTA LATERALE VERSO L'ALTO, ASSICURANDOTI CHE NÈ TU E NÈ NESSUNO INTORNO A TE POSSA ESSERE COLPITO.

- Quando non in uso è possibile risparmiare spazio riponendo il vogatore in posizione verticale. Per fare ciò, solleva lo **stabilizzatore posteriore 02** e solleva il vogatore verso l'alto.
- Se non si prevede di utilizzare il vogatore per più di un mese, svuota il serbatoio dell'acqua prima di riporlo.

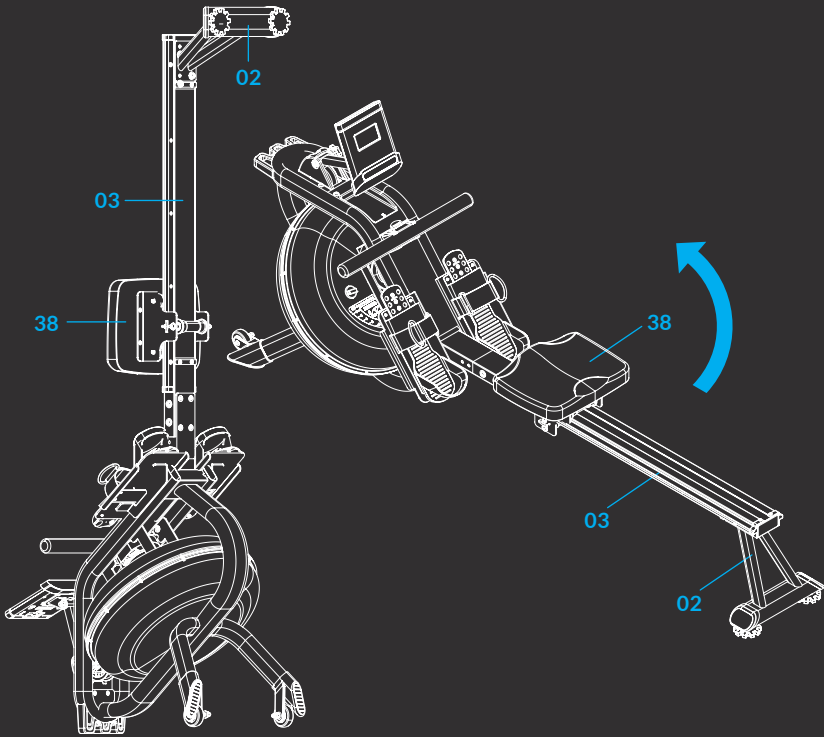



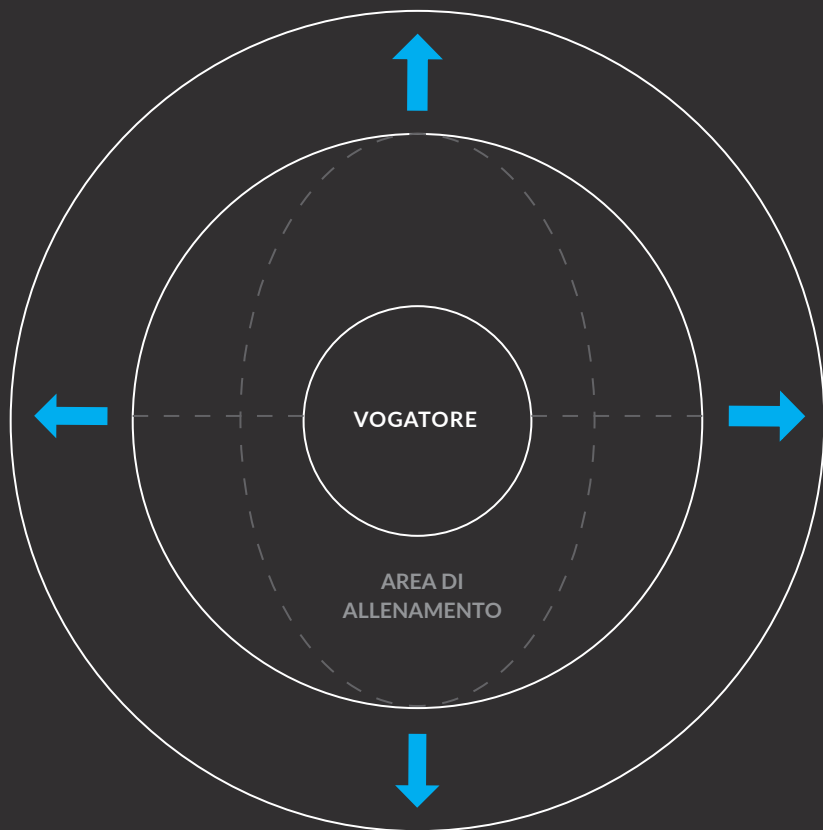

AREA LIBERA DI 0,6 METRI

# FUNZIONI DELLA CONSOLLE

## PULSANTI FUNZIONE

<b>MODE</b>	Premi per selezionare le funzioni. Premi verso il basso per azzerare Tempo/Conteggio Vogate/ Distanza e Calorie per 2 secondi.
<b>SET</b>	Per impostare i valori di Tempo/Conteggio Vogate/Distanza/ Calorie e Pulsazioni quando non si è in modalità di rilevazione.
<b>RESET</b>	Premi verso il basso per azzerare Tempo/Conteggio Vogate/ Distanza/Calorie e Pulsazioni.

## FUNZIONI E OPERAZIONI

Premi il pulsante **MODE**, seleziona **TIME**, a quel punto apparirà la parola **SCAN** sul lato sinistro del monitor. Da qui appariranno sul display per 6 secondi ciascuna tutte le 6 funzioni: **TIME**, **COUNT**, **DISTANCE**, **CALORIE**, **RPM** e **PULSE**.

Quando la funzione desiderata viene visualizzata sullo schermo premi il pulsante **MODE** per scegliere questa funzione e selezionare i parametri che desideri misurare durante l'allenamento.

<b>TIME (TEMPO)</b>	Mostra da quanto tempo dura l'allenamento.
<b>COUNT (CONTEGGIO)</b>	Visualizza la quantità di vogate raggiunte.
<b>DISTANCE (Distanza)</b>	Visualizza la distanza percorsa dall'inizio alla fine dell'esercizio.
<b>CALORIE</b>	Visualizza il numero di calorie bruciate durante l'esercizio.
<b>RPM</b>	Visualizza il numero di vogate al minuto.
<b>PULSE (PULSAZIONI)</b>	Visualizza la frequenza cardiaca in tempo reale durante l'esercizio. <i>La fascia toracica wireless può essere indossata per una misurazione più accurata della frequenza cardiaca.</i>

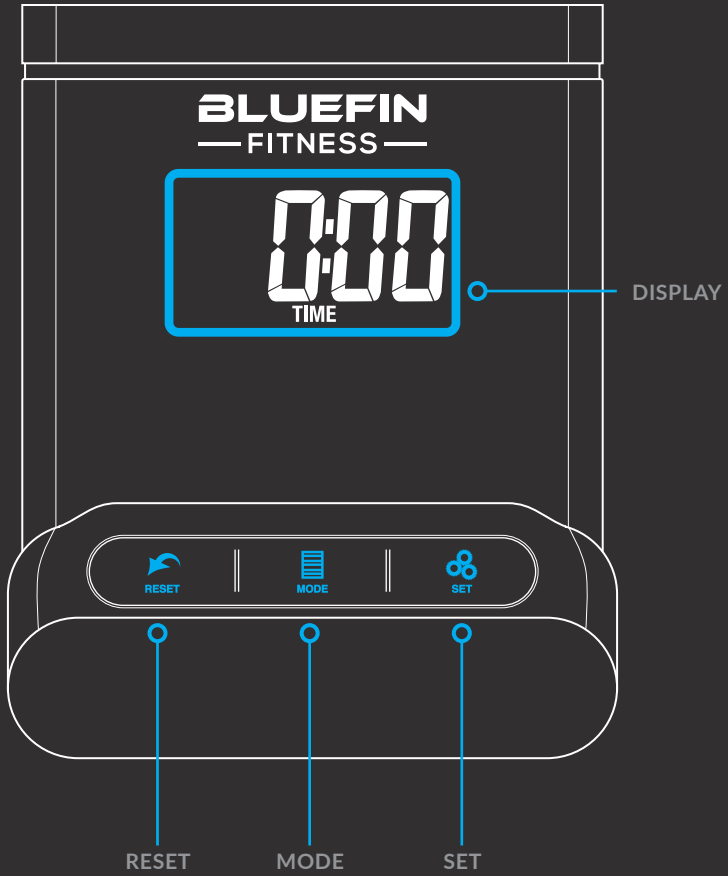

# FUNZIONAMENTO DELLA CONSOLLE

## MODALITÀ DI ALLENAMENTO “TARGET”

Questa consolle ha 5 modalità di allenamento “Target” (a obiettivo): tempo, conteggio, distanza, calorie e polso. Una volta scelta la modalità di allenamento, premi il pulsante MODE per rimuovere la scritta SCAN lampeggiante sul display.

**TEMPO** Premi il pulsante MODE, scegli TIME e premi il pulsante SET per impostare la durata dell'allenamento. È possibile tenere premuto il pulsante per accelerare l'impostazione. Quando hai raggiunto il tempo desiderato, rilascia il pulsante. Una volta che si inizia l'allenamento sul vogatore, il timer partirà e inizierà il conto alla rovescia dalla durata impostata. Una volta che l'obiettivo dell'allenamento è stato completato la consolle emetterà un segnale acustico, segnalando la fine della sessione. Se si continua a vogare il display inizierà automaticamente a contare da zero.

**CONTEGGIO VOGATE** Premi il pulsante MODE, scegli COUNT e premi il pulsante SET per impostare il numero di vogate complete a cui si desideri arrivare. È possibile tenere premuto il pulsante per accelerare l'impostazione. Quando si è raggiunto il conteggio desiderato, rilasciare il pulsante. Una volta che si inizia l'allenamento sul vogatore, il display inizierà il conto alla rovescia dal numero di vogate impostate. Una volta che l'obiettivo dell'allenamento è stato completato la consolle emetterà un segnale acustico, segnalando la fine della sessione. Se si continua a vogare il display inizierà automaticamente a contare da zero.

**DISTANZA** Premi il pulsante MODE, scegli DISTANCE e premi il pulsante SET per impostare la distanza virtuale che desideri raggiungere. È possibile tenere premuto il pulsante per accelerare l'impostazione. Quando si è raggiunto il conteggio desiderato, rilasciare il pulsante. Una volta che si inizia l'allenamento sul vogatore, il display inizierà il conto alla rovescia dalla distanza pre impostata. Una volta che l'obiettivo dell'allenamento è stato completato la consolle emetterà un segnale acustico, segnalando la fine della sessione. Se si continua a vogare il display inizierà automaticamente a contare da zero.

**CALORIE** Premi il pulsante MODALITÀ, scegli CALORIE e premi il pulsante IMPOSTA fino al numero di calorie che desideri bruciare durante l'allenamento. È possibile tenere premuto il pulsante per accelerare l'impostazione. Quando si è raggiunto il conteggio desiderato, rilasciare il pulsante. Una volta che si inizia l'allenamento sul vogatore, il display inizierà il conto alla rovescia dalle calorie pre impostate. Una volta che l'obiettivo dell'allenamento è stato completato la console emetterà un segnale acustico, segnalando la fine della sessione. Se si continua a vogare il display inizierà automaticamente a contare da zero.

**PULSAZIONI** Premi il pulsante MODE, scegli PULSE e premi il pulsante SET per impostare la frequenza cardiaca che desideri raggiungere durante l'allenamento. È possibile tenere premuto il pulsante per accelerare l'impostazione. Una volta che si inizia l'allenamento sul vogatore, il display inizierà il conto alla rovescia dalle pulsazioni pre impostate. Una volta che l'obiettivo dell'allenamento è stato completato la console emetterà un segnale acustico, segnalando la fine della sessione. Se si continua a vogare il display inizierà automaticamente a contare da zero.

È sempre possibile modificare gli obiettivi di allenamento impostati premendo il pulsante RESET per cancellare tutte le impostazioni correnti. Quindi scegli nuovamente gli obiettivi di allenamento con le istruzioni riportate qui sopra.

## FUNZIONAMENTO DELLA CONSOLLE

NB. SE IL DISPLAY È SBIADITO O NON MOSTRA NUMERI, SI PREGA DI SOSTITUIRE LE BATTERIE.

LA CONSOLLE SI SPENGERÀ AUTOMATICAMENTE SE NON VIENE RICEVUTO SEGNALE PER 4 MINUTI.

IL MONITOR SI ACCENDERÀ AUTOMATICAMENTE QUANDO SI INIZIA A UTILIZZARE IL VOGATORE.

IL MONITOR INIZIA AUTOMATICAMENTE A CALCOLARE L'ALLENAMENTO APPENA SI INIZIA A REMARE E FINO A 4 SECONDI DOPO AVER FINITO.

FUNZIONE:	SCANSIONE	Ogni 6 secondi
	TEMPO	0:00~99:59
	CONTEGGIO VOGATE	0~9999 VOLTE
	DISTANZA	0~9999 METRI
	CALORIES	0.0~999.9 CAL
	RPM	0~999 VOLTE/MIN
	PULSAZIONI	40~220 BPM
TIPO DI BATTERIA	2 pezzi -AA o UM-3	
TEMPERATURA DI ESERCIZIO	0°C~ +40°C	
TEMPERATURA DI CONSERVAZIONE	-10°C~ +60°C	



## L'APP PER IL FITNESS KINOMAP

### AGGIUNGERE L'APP

- Cerca KINOMAP nell'app store dello smartphone e scarica.
- Al termine del download, apri l'app KINOMAP e registra i tuoi dati personali.
- Attiva il Bluetooth e assicurati che la console del Blade Aqua sia accesa e attivata.
- Sincronizza il Blade Aqua con l'app KINOMAP come segue:



# 01

Premi Altro (MORE) per visualizzare la pagina Equipaggiamento, seleziona Gestione delle attrezzature. (Equipment Management).

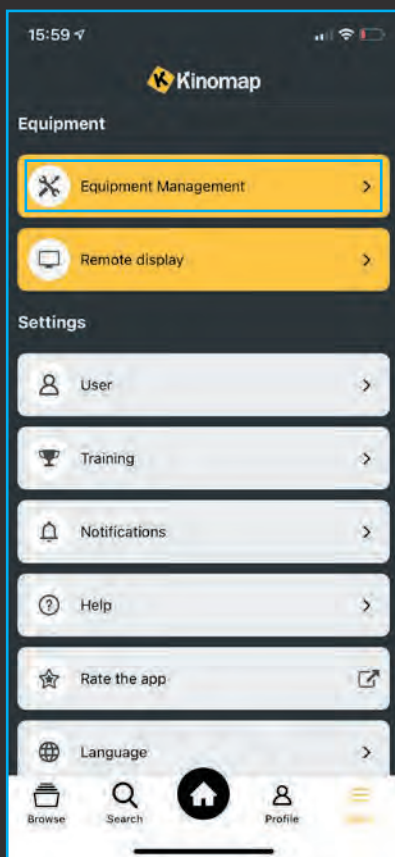

# 02

Premi l'icona +.

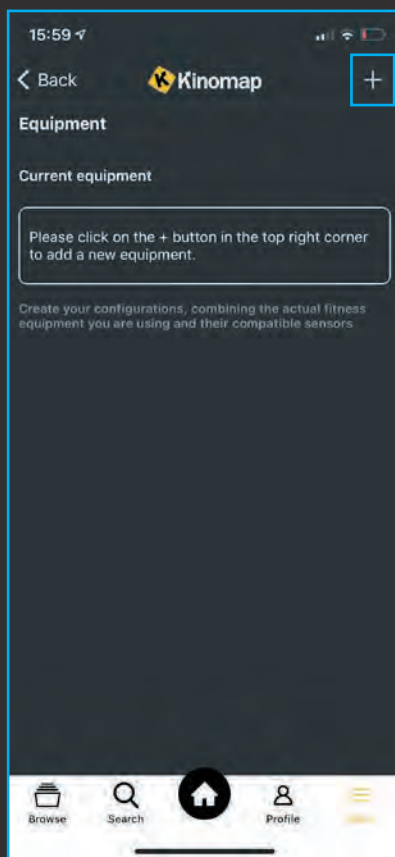

03

Seleziona l'icona Vogatore (ROWING).



04

Seleziona l'icona Bluefin Fitness.

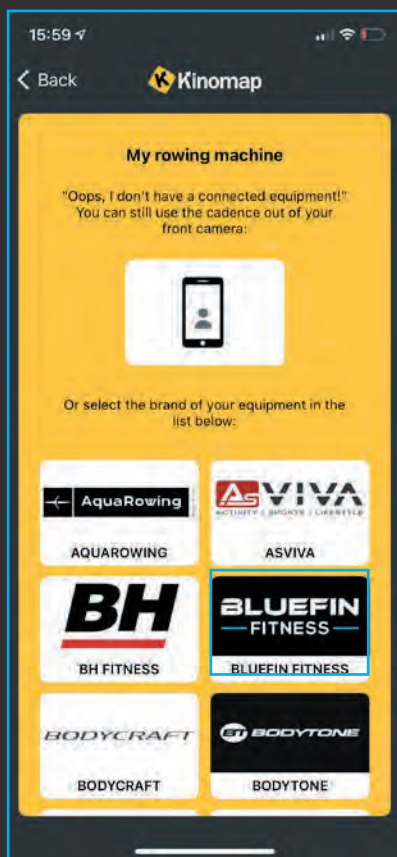

## 05

Seleziona **Blade Aqua M-1**.

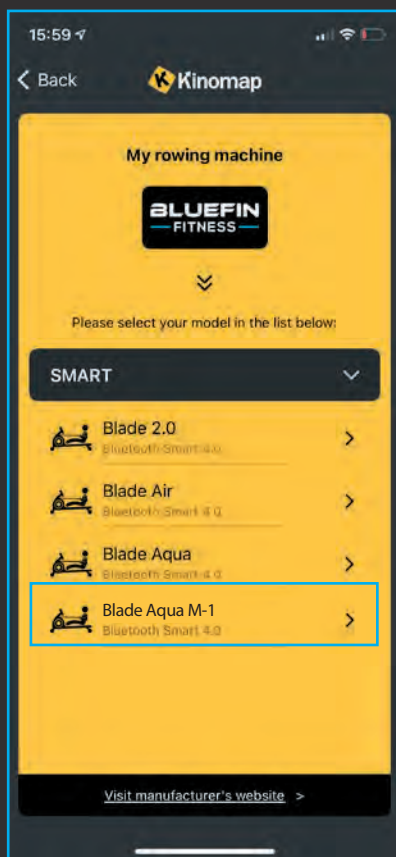

## 06

Aggiungi il tuo **Blade Aqua M-1** per completare, inizia la sessione di allenamento.

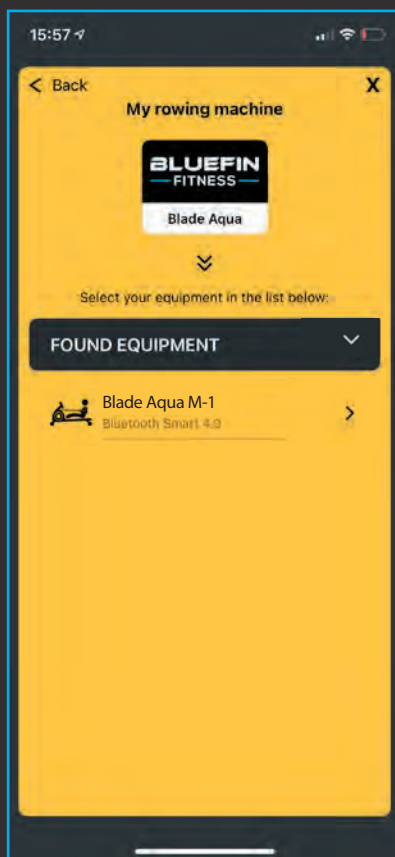

## RISCALDAMENTO E DEFATICAMENTO

PER PREVENIRE GLI INFORTUNI E CONSIGLIABILE SEMPRE RISCALDARSI E DEFATICARSI CON VARI ESERCIZI DI ALLUNGAMENTO MUSCOLARE PRIMA E DOPO OGNI ALLENAMENTO.

CONSIGLIAMO I SEGUENTI ALLUNGAMENTI CHE RIDURRANNO IL RISCHIO DI LESIONI MUSCOLARI O SPASMI DURANTE L'ESERCIZIO. NON ALLUNGARE MAI ECCESSIVAMENTE I MUSCOLI PER EVITARE STRAPPI.

### CURVE LATERALI

Passa un braccio sopra la testa, piegando la parte superiore del corpo nella stessa direzione. Tieni questa posizione per 10-15 secondi e raddrizzati lentamente. Ripeti 3 volte per ogni lato..

### DITA DEI PIEDI

Piegati lentamente in avanti dalla vita, lasciando che la schiena e le spalle si rilassino mentre ti allunghi verso le dita dei piedi. Raggiungi il punto più vicino possibile alle dita dei piedi e tieni la posizione per 15 secondi. Quindi rilassati e ripeti 3 volte.

## STRETCHING POLPACCIO E TENDINE DI ACHILLE

Appoggiati a un muro con la gamba sinistra davanti alla destra e le braccia sul muro. Tieni la gamba destra dritta e il piede sinistro a terra, piega la gamba sinistra e piegati in avanti spostando i fianchi verso il muro. Sentirai tirare il polpaccio e il tallone della gamba destra. Mantieni la posizione, quindi ripetila sull'altra gamba per 15 secondi. Ripeti 3 volte per ogni gamba.

## STRETCHING DEL QUADRICIPITE

Con una mano contro un muro per mantenere l'equilibrio, allunga la mano dietro di te e solleva il piede destro. Porta il tallone il più vicino possibile ai glutei. Tieni premuto per 10-15 secondi. Ripeti tre volte per ogni piede.

## STRETCHING INTERNO COSCIA

Siediti con le piante dei piedi unite e le ginocchia rivolte verso l'esterno. Tira i piedi il più vicino possibile all'inguine. Spingi delicatamente le ginocchia verso il pavimento. Tieni premuto per 15 secondi. Quindi rilassati e ripeti 3 volte.

## ESERCIZI CON IL VOGATORE

### UTILIZZARE REGOLARMENTE IL TUO VOGATORE PERMETTE DI:

- Migliorare la forma fisica generale, rafforzando il cuore e migliorando circolazione oltre a tenere in esercizio tutti i principali gruppi muscolari: schiena, vita, braccia, spalle, fianchi e gambe.
- Tonificare i muscoli e, in combinazione con una dieta ipocalorica, aiuterà a perdere peso. Il canottaggio con il vogatore è una forma di esercizio estremamente efficace.

### ESERCIZIO BASE CON IL VOGATORE

- Siediti sul sedile e allaccia i piedi ai pedali tramite le cinghie. Afferra la barra di canottaggio.
- Assumi la posizione di partenza, piegandoti in avanti con le braccia tese e le ginocchia piegate come mostrato in **Fig 1**.
- Spingiti indietro, raddrizzando la schiena e le gambe allo stesso tempo come in **Fig 2**.
- Continua questo movimento finché non sei leggermente inclinato all'indietro. Durante questa fase devi distendere le braccia come in **Fig 3**. Quindi torna alla fase 2 e ripeti.

### INTENSITÀ DELL'ALLENAMENTO

- Il canottaggio è una forma di esercizio faticoso, quindi è meglio iniziare l'allenamento con una resistenza bassa e per brevi periodi se sei un principiante. Man mano che avanzi puoi aumentare la resistenza e il tempo di allenamento in base alle tue esigenze e ai tuoi obiettivi di fitness.

Si consiglia di iniziare con un allenamento a giorni alterni, circa 3 volte a settimana, per dare al tuo corpo il tempo di recuperare tra un allenamento e l'altro.

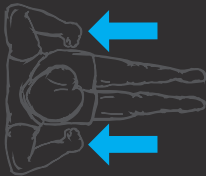

Fig 1



Fig 2



Fig 3

## ESERCIZI CON IL VOGATORE

### STILI DI VOGA ALTERNATIVI

#### VOGA SOLO CON LE BRACCIA

Questo stile di voga tonificherà i muscoli di braccia, spalle, schiena e stomaco. Siediti come mostrato in **Fig 4** con le gambe dritte, piegati in avanti e afferra le maniglie. In modo graduale e controllato sposta il busto all'indietro appena oltre la posizione eretta continuando a tirare le maniglie verso il petto. Ritorna alla posizione di partenza e ripeti.

#### VOGA SOLO CON LE GAMBE

Questo esercizio tonifica i muscoli delle gambe e della schiena. Con la schiena dritta e braccia tese, piega le gambe fino ad afferrare le maniglie del vogatore nella posizione di partenza, come in **Fig 7**. Usa le gambe per spingere il tuo corpo indietro mantenendo le braccia e la schiena dritte.

#### TONO MUSCOLARE

Il modo più efficace per tonificare i muscoli mentre si rema è impostare un'elevata resistenza facendo attenzione a non provocarsi lesioni sollecitando eccessivamente i muscoli. Consigliamo sempre di riscaldarsi e defaticarsi con una resistenza leggera e di aumentare la resistenza nella parte finale dell'allenamento quando i muscoli si sono riscaldati correttamente.

#### PERDITA DI PESO

Maggiore è lo sforzo che si mette nell'allenamento di voga, più calorie si bruciano. Aumenta gradualmente la resistenza, la durata e lo sforzo in ogni allenamento, questi fattori aiutano a perdere peso.



Fig 4



Fig 5



Fig 6



Fig 7



Fig 8



Fig 9

## GARANZIA DEL PRODUTTORE

📧 LA GARANZIA BLUEFIN COPRE EVENTUALI GUASTI TECNICI DELL'ATTREZZO. SE SI HA BISOGNO DI EFFETTUARE UN RECLAMO IN GARANZIA CONTATTARCI VIA EMAIL A: [SUPPORT@BLUEFINTRADING.CO.UK](mailto:SUPPORT@BLUEFINTRADING.CO.UK)

### LA GARANZIA NON COPRE QUANTO SEGUE:

- Usura generale e segni d'uso.
- Danno idrico.
- Danni per uso improprio.
- Danni al telaio e graffi dovuti a un uso improprio o cadute dell'attrezzo.
- Danni elettronici dovuti a uso improprio o cadute dell'attrezzo.
- La garanzia inizia alla ricezione a casa del prodotto.
- I guasti tecnici sono coperti per 12 mesi.

In caso di domande sulla garanzia, inviare un'e-mail a: [support@bluefintrading.co.uk](mailto:support@bluefintrading.co.uk)



William Vaughan, CEO  
Bluefin Trading Ltd.

## DICHIARAZIONE DI CONFORMITÀ UE

Per la dichiarazione di conformità UE più recente e aggiornata di questo prodotto visita: [www.bluefinfitness.com/manuals/bladeaqua\\_m1\\_DoC.pdf](http://www.bluefinfitness.com/manuals/bladeaqua_m1_DoC.pdf)

Importer Address:  
Bluefin Trading Ltd  
Keelham Farm  
Hebden Bridge  
UK  
HX7 8TG  
[www.bluefinfitness.com](http://www.bluefinfitness.com)



### RIFIUTI DA APPARECCHIATURE ELETTRICHE ED ELETTRONICHE

Non smaltire questo dispositivo con i rifiuti domestici. I componenti del dispositivo devono essere riciclati separatamente o smaltiti secondo le normative locali. L'utilizzatore può anche restituire al produttore eventuali apparecchiature elettriche ed elettroniche di scarto alla fine del loro ciclo di vita. Le spese sostenute per il trasporto al produttore saranno a carico del proprietario dei rifiuti da apparecchiature elettriche ed elettroniche.



### DIRETTIVA BATTERIE

Non smaltire le batterie con i rifiuti domestici. Riciclare o smaltire in sicurezza le batterie in conformità con le normative locali. Eventuali batterie fornite dal produttore o dal distributore possono essere restituite alla fine del loro ciclo di vita per il riciclaggio e lo smaltimento sicuro. Le spese sostenute per il trasporto verso il produttore o il distributore saranno a carico del proprietario delle batterie.



### RICICLAGGIO DEI MATERIALI DI IMBALLAGGIO

Non smaltire gli imballaggi con i rifiuti domestici. Tutti i materiali di imballaggio possono essere riciclati in sicurezza secondo le normative locali.

# BLADE AQUA



M-1 WATER RESISTANCE ROWER

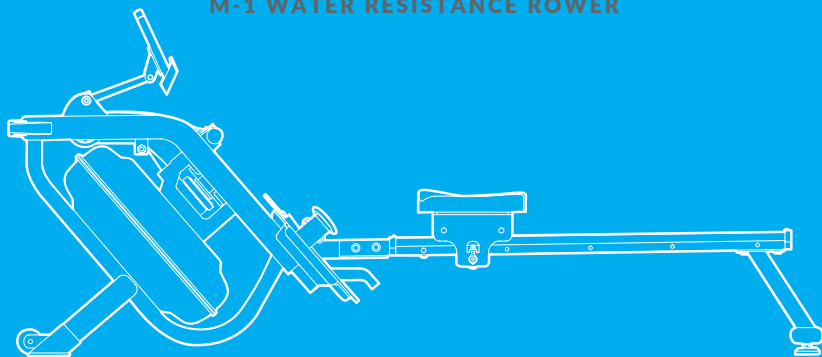



## WELKOM BIJ DE BLUEFIN FITNESS COMMUNITY

BEDANKT VOOR JE AANKOOP VAN DE BLUEFIN FITNESS BLADE AQUA M-1 ROEITRAINER. ZORG ERVOOR DAT ALLE PERSONEN DIE DE ROEITRAINER ZULLEN GEBRUIKEN DE HANDLEIDING ZORGVULDIG NALEZEN EN BEGRIJPEN. OP DIE MANIER HAAL JE HET MEESTE UIT JE NIEUWE TOESTEL.

BLUEFIN FITNESS AANVAARDT GEEN AANSPRAKELIJKHEID VOOR SCHADE BIJ ONAANGEPAST OF VERKEERD GEBRUIK.

WE WENSEN JE VEEL PLEZIER MET DE NIEUWE BLADE AQUA M-1 ROEITRAINER. WIL JE OP DE HOOGTE BLIJVEN VAN ONS STEEDS GROTER WORDENDE ASSORTIMENT FITNESSSTOESTELLEN, NEEM DAN EEN KIJKJE OP ONZE WEBSITE: [BLUEFINFITNESS.COM](https://bluefinfitness.com) EN VOLG ONS OP SOCIAL MEDIA:

**FACEBOOK** [FACEBOOK.COM/BLUEFINFITNESS](https://facebook.com/bluefinfitness)

**INSTAGRAM** [@BLUEFINFITNESS](https://instagram.com/bluefinfitness)

**TWITTER** [@BLUEFIN\\_FITNESS](https://twitter.com/bluefin_fitness)

**LINKEDIN** [LINKEDIN.COM/BLUEFIN-FITNESS](https://linkedin.com/company/bluefin-fitness)

HET BLUEFIN FITNESS-TEAM.

## VEILIGHEIDSMATREGELEN

**i ZORG ERVOOR DAT ALLE PERSONEN DE BLADE AQUA HANDLEIDING HEBBEN GELEZEN EN BEGREPEN VOOR GEBRUIK.**

**HOU DEZE HANDLEIDING ZORGVULDIG BIJ.**

De volgende algemene veiligheidsregels moeten in acht worden genomen bij het gebruik van de Blade Aqua.

- Raadpleeg altijd je arts voordat je met een trainingsprogramma begint en hou rekening met eventuele medische of lichamelijke aandoeningen die je gezondheid en veiligheid in gevaar kunnen brengen, vooral als je medicatie gebruikt voor je hart, bloeddruk of cholesterolgehalte.
- Stop onmiddellijk met trainen als je één van de volgende symptomen ervaart tijdens je work-out: scherpe pijn, benauwd gevoel op de borst, onregelmatige hartslag, kortademigheid, duizeligheid of misselijkheid. Als je één van de bovenstaande symptomen ervaart, raadpleeg dan je arts vooraleer je verder traint.
- Houd kinderen en dieren altijd uit de buurt van de roeitrainer. Het toestel is enkel bedoeld voor gebruik door volwassenen.
- Plaats de roeitrainer op een stevige, vlakke ondergrond, bij voorkeur met een beschermhoes, om de vloer te beschermen. Zorg voor minimaal 60 cm vrije ruimte rondom het toestel.
- Zorg ervoor dat alle moeren en bouten stevig vastzitten voordat je de roeitrainer gebruikt.
- Controleer het toestel regelmatig op schade en/of slijtage om de algemene veiligheidsvoorwaarden te handhaven.

- Als je defecte onderdelen aantreft tijdens het monteren van het toestel, of als de roeitrainer ongewone geluiden maakt tijdens het trainen, stop dan onmiddellijk. Gebruik het toestel niet totdat het probleem is opgelost.
- Draag geschikte kleding tijdens de training. Vermijd loszittende kleding die vast kan komen te zitten.
- Steek geen vingers of kleine voorwerpen in de bewegende delen van het toestel.
- De maximale draaglast van van dit toestel is 150 kg.
- Wees voorzichtig bij het verplaatsen van de roeitrainer. Zoek, indien nodig, hulp.
- Berg de roeitrainer niet op op plaatsen met extreme temperaturen of omstandigheden, waaronder vochtige ruimtes. Dit kan leiden tot roest en operationele problemen.
- Dit toestel is uitsluitend ontworpen voor gebruik binnenshuis en thuis. Het is niet bedoeld voor commercieel gebruik..

**⚠ WAARSCHUWING: ALS JE OUDER BENT DAN 45 JAAR OF KAMPT MET GEZONDHEIDSPROBLEMEN, RAADPLEEG DAN EERST JE ARTS VOORDAT JE DIT TOESTEL GEBRUIKT.**

**BLUEFIN FITNESS AANVAARDT GEEN AANSPRAKELIJKHEID VOOR PERSOONLIJK LETSEL OF SCHADE AAN EIGENDOMMEN, VEROORZAAKT DOOR DIT PRODUCT OF DOOR HET GEBRUIK ERVAN.**

## ONDERDELEN

**i** ZORG ERVOOR DAT DE VOLGENDE ONDERDELEN AANWEZIG ZIJN VOORDAT JE DE BLADE AQUA M-1 MONTEERT :

P.S. SOMMIGE KLEINE ONDERDELEN ZIJN REEDS VOORGEMONTEERD OP GROTERE DELEN OM HET TOESTEL SNELLER TE INSTALLEREN.



19 **x1**



20 **x1**



80 M8 **x1**



59 M8\*15 **x4**



61 M4\*12 **x2**



62 M8\*15 **x4**



68 M8\*15 **x8**



72 M6\*10 **x2**



66 M8\*65 **x4**



74 OD20\*ID8.5\*1.5 **x8**

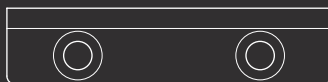

40 **x1**



93 S5 **x1**



94 S13-17 **x1**

## CHECKLIST VOORALEER AAN DE MONTAGE TE BEGINNEN:

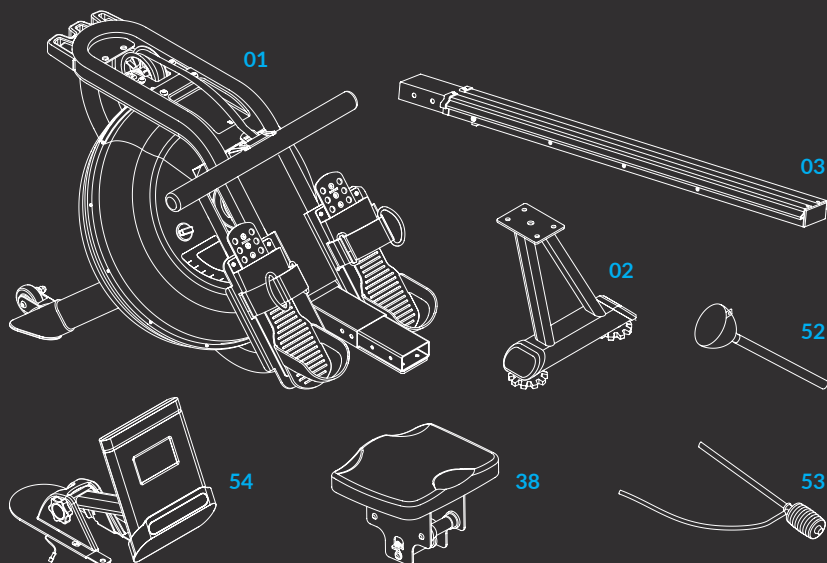

ONDERDEEL	BESCHRIJVING	AANTAL
01	Hoofdframe	x1
02	Achterste stabilisator	x1
03	Schuifrail	x1
38	Zitje	x1
52	Trechter	x1
53	Hevelpomp	x1
54	Bedieningspaneel	x1

# 01

## MONTAGE-INSTRUCTIES

ⓘ **OPMERKING: WE RADEN AAN OM HET TOESTEL TE MONTEREN MET TWEE PERSONEN.**

- Schuif Zitje **38** op Schuifrail **03**.
- Zet Nummer **40** vast met 2 Platte Kruisschroeven **72**.
- Bevestig de Achterste Stabilisator **02** aan Schuifrail **03** met 4 ringen **74** en 4 zeskantschroeven **59**.
- Draai vast met Moersleutel **94**.



**72** M6\*10 **x2**



**59** M8\*15 **x4**



**94** S13-17 **x1**



**74** OD20\*ID8.5\*1.5 **x4**

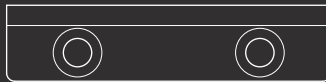

**40** **x1**

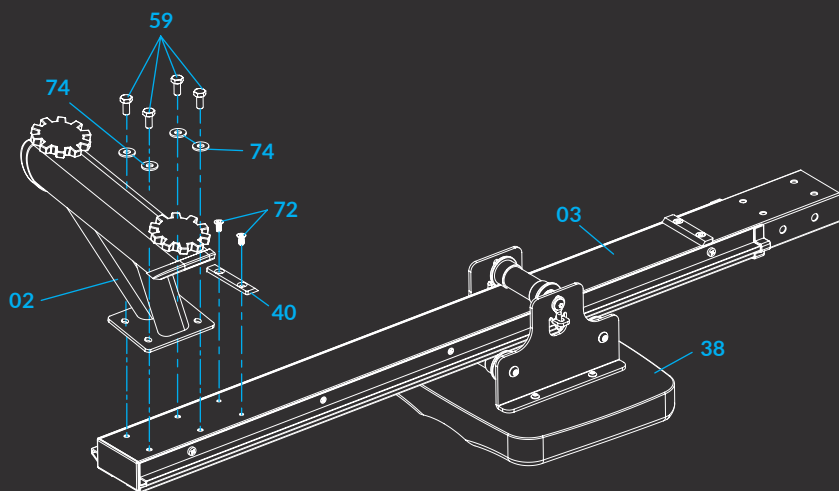

# 02

## MONTAGE-INSTRUCTIES

- Zet het decoratieve links/rechts gedeelte voor Rail 19 en 20 vast met 2 Kruisschroeven 61 op Schuifrail 03.  
Draai vast met Moersleutel 94.



19 x1



20 x1



61 M4\*12 x2



94 S13-17 x1

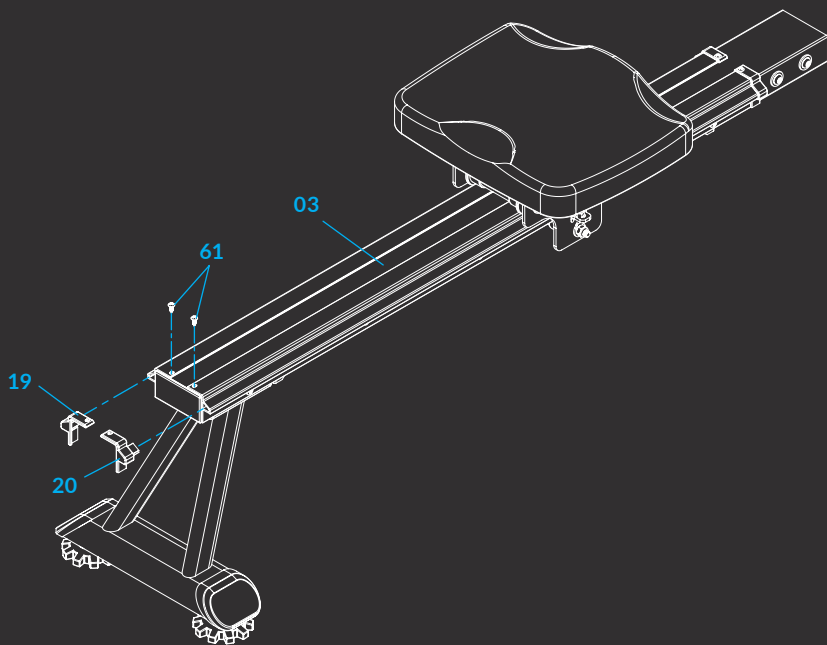

# 03

## MONTAGE-INSTRUCTIES

① VERPLAATS HET ZITJE 38 NAAR HET VOORSTE GEDEELTE VAN DE SCHUIFRAIL 03 VOORALEER VERDER TE GAAN, OM TE VOORKOMEN DAT HET ZITJE TIJDENS DE MONTAGE VERSCHUIFT..

- Bevestig **Schuifrail 03** aan **Hoofdframe 01** met behulp van **4 ringen 74**, **4 Schroeven 68** en **4 Platte Schroeven 62**.
- Steek eerst alle 8 schroeven gedeeltelijk in de gaten en draai ze vervolgens vast met **Inbussleutel 93**.



62 M8\*15 **x4**



68 M8\*15 **x4**



74 OD20\*ID8,5\*1,5 **x4**



93 S5 **x1**

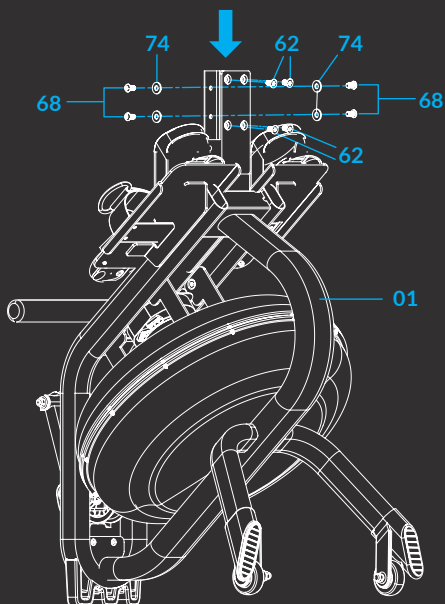
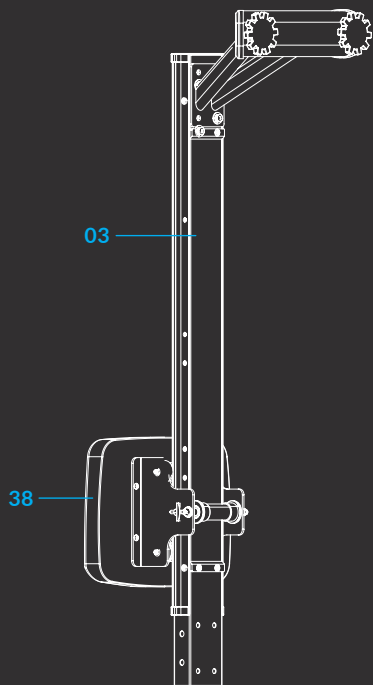

# 04

## MONTAGE-INSTRUCTIES

- Bevestig vervolgens de ondersteuning voor het **bedieningspaneel 54** aan het **Hoofdframe 01** en zorg ervoor dat de draden zijn aangesloten. Draai alles vervolgens vast met **4 schroeven 68** en **inbussleutel 93**.



**66** M8\*65 **x4**



**80** M8 **x1**



**94** S13-17 **x1**



**93** S5 **x1**



**74** OD20\*ID8.5\*1.5 **x2**

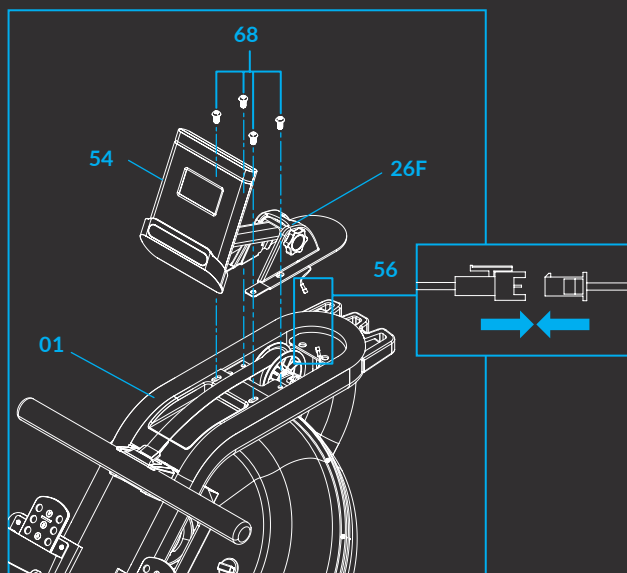

Ontgrendelen



Vergrendelen

Draai 3 groeven naar links om te ontgrendelen, pas de hoek van het Bedieningspaneel 54 aan en draai vervolgens naar rechts om het te vergrendelen.

# 05

## WATERRESERVOIR

GEBRUIK NOOIT ZWEMBADCHLOOR OF CHLOORBLEEKMIDDEL OM HET WATERRESERVOIR TE VULLEN, DIT ZAL HET RESERVOIR BESCHADIGEN EN DE GARANTIE ZAL VERVALLEN.

VOEG ELKE 2-3 MAANDEN 1 WATERZUIVERINGSTABLET TOE, OF ZO VAAK NODIG. VERVANG HET WATER IN HET RESERVOIR ALS HET TROEBEL WORDT.

DRINK NOOIT WATER UIT HET RESERVOIR. VERWIJDER HET WATER ALTIJD MET DE HEVELPOMP EN VERWIJDER HET OP EEN VEILIGE MANIER.

### VULLEN EN LEDIGEN

- Verwijder de **Vulschroef 50** van het bovenste **Reservoir 24**.
- Om de tank met water te vullen, zie **Afb. A**.  
Plaats **Trechter 52** in de tank en gebruik vervolgens een beker of **Hevelpomp 53** en een emmer om het reservoir met water te vullen. Gebruik de waterniveaumeter aan de zijkant van het reservoir om het gewenste waterniveau te meten.
- Om de tank te ledigen, zie **Afb. B**.
- Plaats een emmer naast de roeitrainer, en gebruik **Hevelpomp 53** om het water uit de tank in de emmer te pompen.
- Steek **Vulschroef 50** in het bovenste **Reservoir 24**.  
Verwijder overtollig water van het frame.

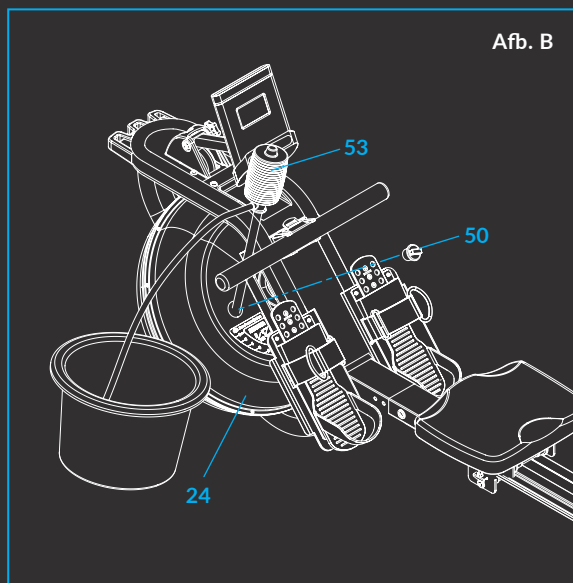
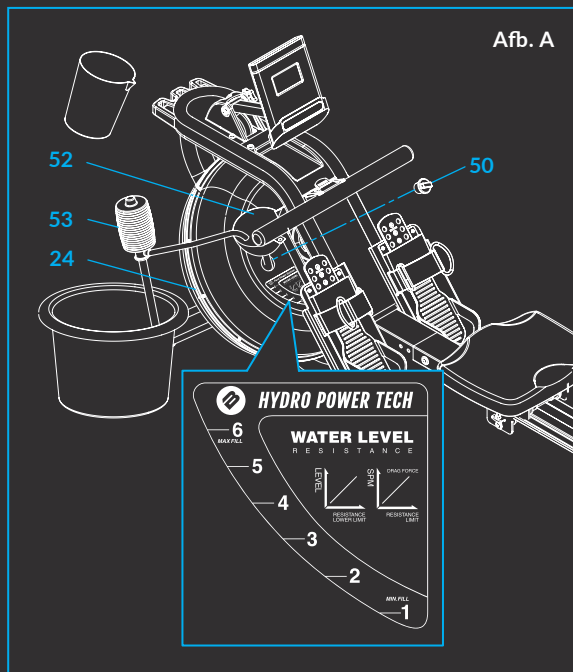

## WATERRESERVOIR

### VERZORGING EN ONDERHOUD

- Waterzuiveringstabletten helpen de kwaliteit van het water te behouden.
- Gebruik gedestilleerd water om het reservoir te vullen.
- Begin te roeien zodra je de waterzuiveringstablet in het waterreservoir hebt geplaatst, om ervoor te zorgen dat de tablet oplost.
- Elke waterzuiveringstablet bevat ongeveer 167 mg natriumdichloorisocyanuraat. Vermijd elk contact met metalen voorwerpen om corrosie of roest te voorkomen..

**⚠ WATERZUIVERINGSTABLETTELEN ZIJN NIET BIJ HET PRODUCT INBEGREPEN WEGENS BEPERKINGEN OP INTERNATIONALE VERZENDING. KOOP WATERZUIVERINGSTABLETTELEN BIJ EEN BETROUWBARE LOKALE HANDELAAR OF ONLINE.**



# 06

## DE BLADE AQUA VERPLAATSEN

- Til de achterste **stabilisator 02** op om de roeitrainer te verplaatsen, totdat **Wielen 18** op de voorste stabilisator de grond raken.
- Verplaats de roeitrainer voorzichtig naar de gewenste locatie, met de wielen op de grond.

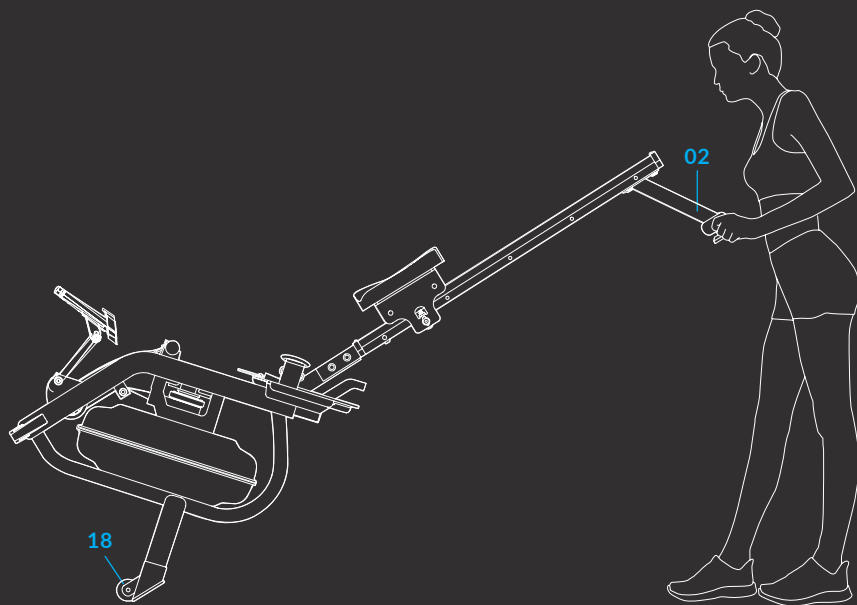

## DE BLADE AQUA STABILISEREN

 **WEES VOORZICHTIG! HOU JE HANDEN WEG VAN DE SCHUIFRAIL, DE BEWEGING VAN HET ZITJE KAN LETSELS VEROORZAKEN.**

- Mocht de machine tijdens het gebruik uit balans raken, stel dan **Afstelknop 23** af onder de **Achterste stabilisator 02** om de roeitrainer te stabiliseren.

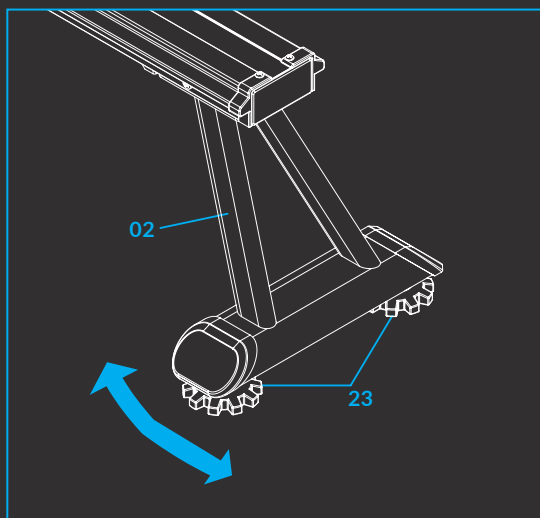

## DE AQUA BLADE OPBERGEN

⚠ P.S. ZORG ERVOOR DAT JE ZITJE 38 NAAR HET VOORSTE GEDEELTE VAN SCHUIFRAIL 3 VERPLAATST WANNEER JE DE ROEITRAINER OPHEFT, ZODAT HET ZITJE NIET VERSCHUIFT TIJDENS HET VERPLAATSEN.

⚠ KLAP VOORZICHTIG DE SCHUIFRAIL OMHOOG.

- Wanneer je de roeitrainer niet gebruikt, kun je hem verticaal opbergen om ruimte te besparen. Til hiervoor de achterste **stabilisator 02** op en breng de roeitrainer omhoog.
- Als je van plan bent de roeitrainer langer dan een maand niet te gebruiken, ledig dan eerst het reservoir voordat je het toestel opbergt

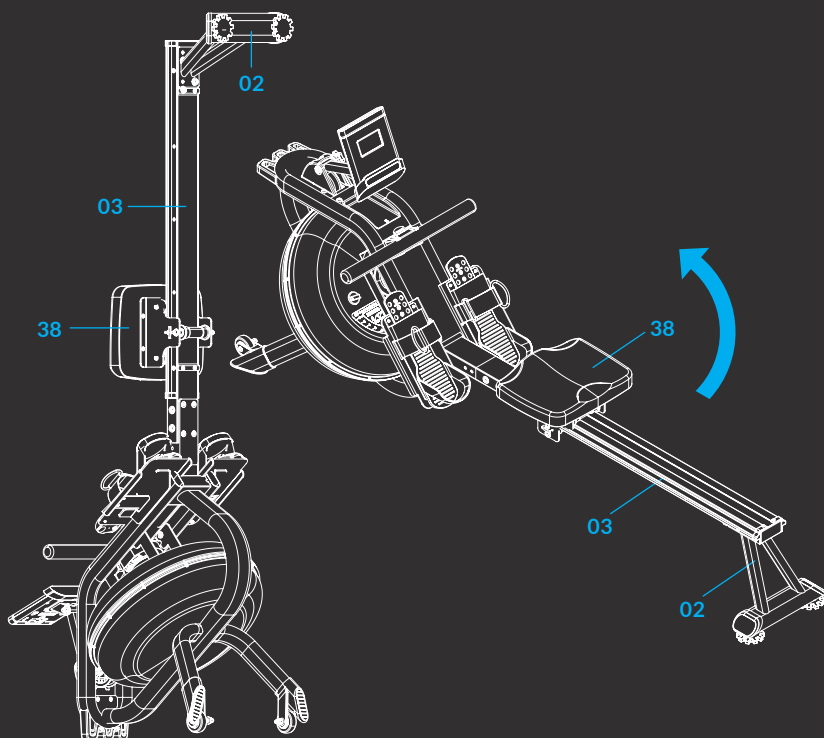

## **BENODIGDE RUIMTE VOOR EEN WORK-OUT**

① ZORG ALTIJD VOOR EEN MINIMUM VAN 60 CM VRIJE RUIMTE RONDOM DE ROEITRAINER, ZODAT JE IN GEVAL VAN NOOD HET TOESTEL KAN VERLATEN.

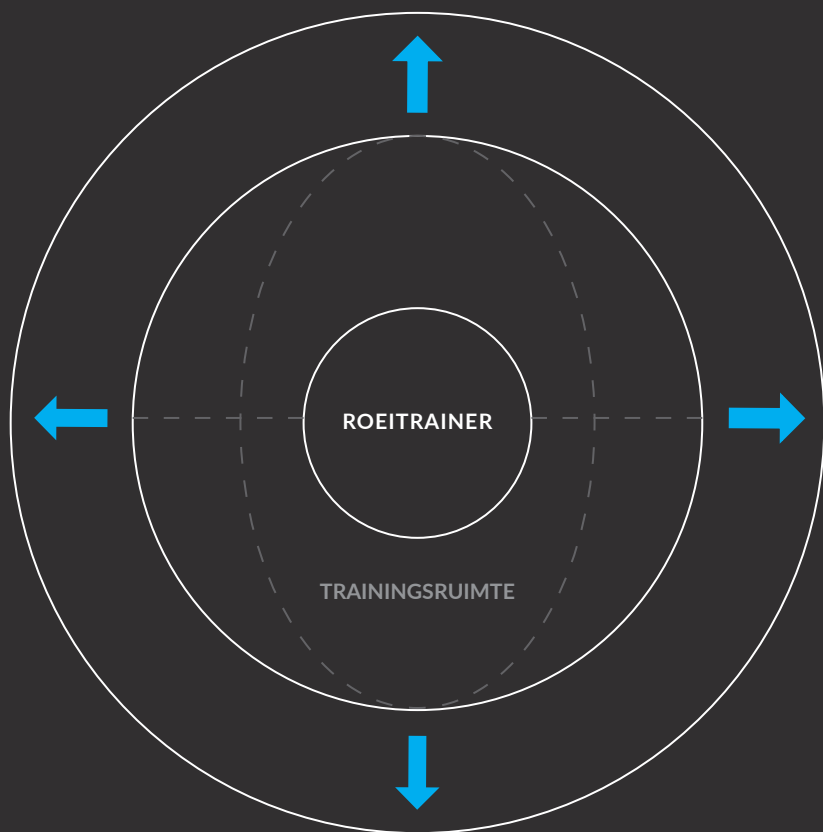

0.6 METER VRIJE RUIMTE

# BEDIENINGSPANEEL

## KNOPPEN

<b>MODE</b>	Druk omlaag om functies te selecteren. Druk 2 seconden omlaag om Tijd/Telling/Afstand en Calorieën te resetten
<b>SET</b>	Om de waarden van Tijd/Telling/Afstand/Calorieën en Hartslag in te stellen wanneer het toestel niet in scanmodus is.
<b>RESET</b>	Druk omlaag om Tijd/Telling/Afstand/Calorieën en Hartslag te resetten

## FUNCTIES EN BEDIENING

Druk op de MODE-knop, selecteer TIME, en het woord 'SCAN' verschijnt aan de linkerkant van de monitor. Daarna verschijnen alle 6 functies op het display gedurende 6 seconden: TIME, COUNT, DISTANCE, CALORIE, RPM en PULSE.

Druk op de MODE-knop om de gewenste functie te kiezen en de parameters te selecteren die je tijdens je training wilt meten.

<b>TIME (TIJD)</b>	Geeft weer hoe lang je aan het trainen bent.
<b>COUNT (TELLING)</b>	Geeft het aantal roeislagen weer.
<b>DISTANCE (AFSTAND)</b>	Toont de afgelegde afstand van het begin tot het einde.
<b>CALORIES (CALORIEËN)</b>	Toont het aantal verbrande calorieën tijdens de training.
<b>RPM</b>	Geeft het aantal roeislagen weer per minuut
<b>PULSE (HARTSLAG)</b>	Geeft je huidige hartslag weer tijdens de training. <i>Je kunt ook kiezen om de draadloze hartslagborstband te dragen voor een meer nauwkeurige hartslagmeting.</i>

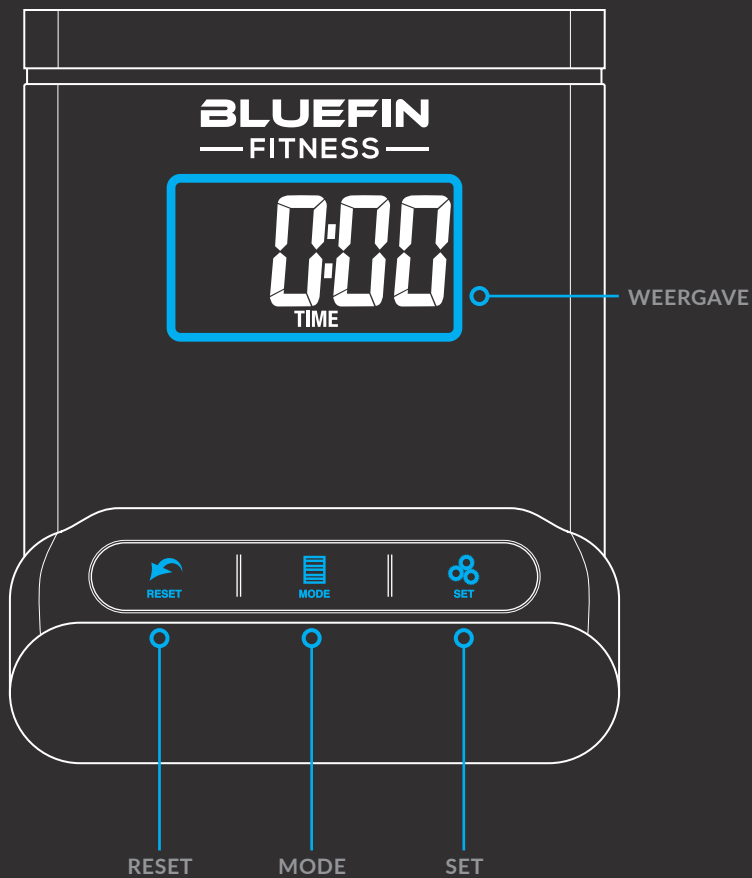

# BEDIENINGSPANEEL

## TRAININGSMODI

Het toestel beschikt over vijf trainingsmodi: Time, Count, Distance, Calories en Pulse. Kies de gewenste trainingsmodus en druk op de MODE-knop om de knipperende SCAN op het display te verwijderen.

**TIME/TIJD** Druk op de MODE-knop, kies TIME en druk op de SET-knop om in te stellen hoe lang je wilt trainen. Je kunt de knop ingedrukt houden om het instellen te versnellen. Laat de knop los wanneer je de gewenste tijd hebt bereikt. Zodra je begint te roeien, begint de timer en wordt er afgeteld vanaf de ingestelde tijdsduur. Zodra je doel is bereikt, piept de console om het einde van je training aan te geven. Als je verder roeit, begint het display automatisch terug vanaf nul te tellen.

**COUNT/TELLING** Druk op de MODE-knop, kies COUNT en druk op de SET-knop om het aantal roeislagen in te stellen dat je wilt bereiken. Je kunt de knop ingedrukt houden om het instellen te versnellen. Laat de knop los wanneer je het vereiste aantal hebt bereikt. Zodra je begint te roeien, begint het display af te tellen vanaf de ingestelde streefwaarde. Zodra het trainingsdoel is bereikt, piept de console om het einde van je training aan te geven. Als je verder roeit, begint het display automatisch terug vanaf nul te tellen.

**DISTANCE/AFSTAND** Druk op de MODE-knop, kies DISTANCE en druk op de SET-knop om de afstand in te stellen die je wilt bereiken. Je kunt de knop ingedrukt houden om het instellen te versnellen. Laat de knop los wanneer je de gewenste afstand hebt bereikt. Zodra je begint te roeien, begint het display af te tellen vanaf de ingestelde afstand. Zodra het trainingsdoel is bereikt, piept de console om het einde van je training aan te geven. Als je verder roeit, begint het display automatisch terug vanaf nul te tellen.

**CALORIES/CALORIEËN** Druk op de MODE-knop, kies CALORIES, en druk op de SET-knop om het aantal calorieën dat je tijdens je training wilt verbranden, in te stellen. Je kunt de knop ingedrukt houden om het instellen te versnellen. Laat de knop los wanneer je het gewenste aantal calorieën hebt bereikt. Zodra je begint te roeien, begint het display af te tellen vanaf de ingestelde streefwaarde. Zodra het trainingsdoel is bereikt, piept de console om het einde van je training aan te geven. Als je verder roeit, begint het display automatisch terug vanaf nul te tellen.

**PULSE/HARTSLAG** Druk op de MODE-knop, kies PULSE en druk op de SET-knop om de hartslag in te stellen die je tijdens je training wilt bereiken. Je kunt de knop ingedrukt houden om het instellen te versnellen. Laat de knop los wanneer je de gewenste hartslag hebt bereikt. Zodra je begint te roeien, begint het display af te tellen vanaf de ingestelde hartslag. Zodra het trainingsdoel is bereikt, piept de console om het einde van je training aan te geven. Als je verder roeit, begint het display automatisch terug vanaf nul te tellen.

Je kunt de ingestelde trainingsdoelen altijd wijzigen door op de RESET-knop te drukken om alle huidige instellingen te wissen. Via de bovenstaande instructies kun je nieuwe trainingsdoelen instellen.

## BEDIENINGSPANEEL

P.S. VERVANG DE BATTERIJEN VAN HET DISPLAY ALS HET BEELD ONDUIDELIJK IS OF WANNEER ER GEEN CIJFERS WEERGEGEVEN WORDEN,

DE CONSOLE WORDT AUTOMATISCH UITGESCHAKELD ALS ER NA 4 MINUTEN GEEN SIGNAAL IS ONTVANGEN.

DE MONITOR WORDT AUTOMATISCH INGESCHAKELD WANNEER JE BEGINT TE ROEIEN.

DE MONITOR BEGINT AUTOMATISCH MET HET BEREKENEN VAN WAARDEN ZODRA JE BEGINT MET ROEIEN, EN TOT 4 SECONDEN NA HET EINDE.

FUNCTIE:	SCAN	Elke 6 seconden
	TIJD	0:00-99:59
	TELLING	0-9999 KEER
	AFSTAND	0-9999 METER
	CALORIEËN	0.0-999.9 CAL
	RPM	0-999 KEER/MIN
	HARTSLAG	40-220 BPM
BATTERIJ TYPE		2 AA OF 2 UM-3
BEDRIJFSTEMPERATUUR		0°C- +40°C
OPSLAGTEMPERATUUR		-10°C- +60°C



## KINOMAP FITNESS-APP

### DE APP TOEVOEGEN

- Zoek KINOMAP in de app store van je smartphone en download de app.
- Open de KINOMAP-app en registreer je persoonlijke gegevens.
- Schakel Bluetooth in en zorg ervoor dat de Blade Aqua-console is ingeschakeld
- Synchroniseer de Blade Aqua met de KINOMAP-app door de volgende stappen te volgen:



## 01

Druk op 'Meer' om de 'Toestel'-pagina te openen, selecteer **Toestelbeheer**

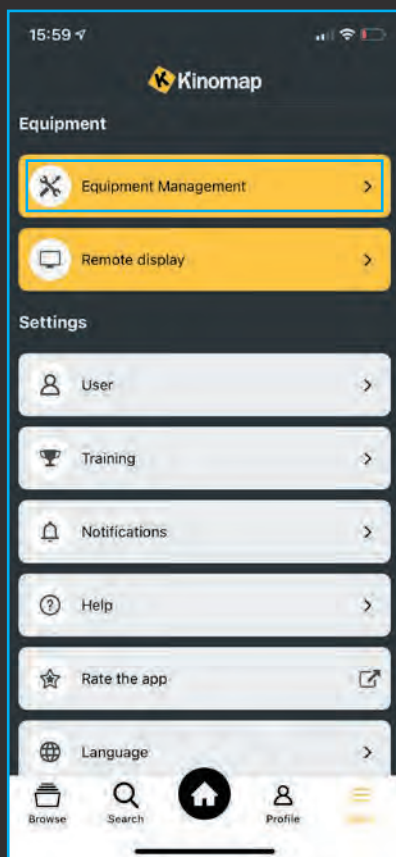

## 02

Druk op het + teken.

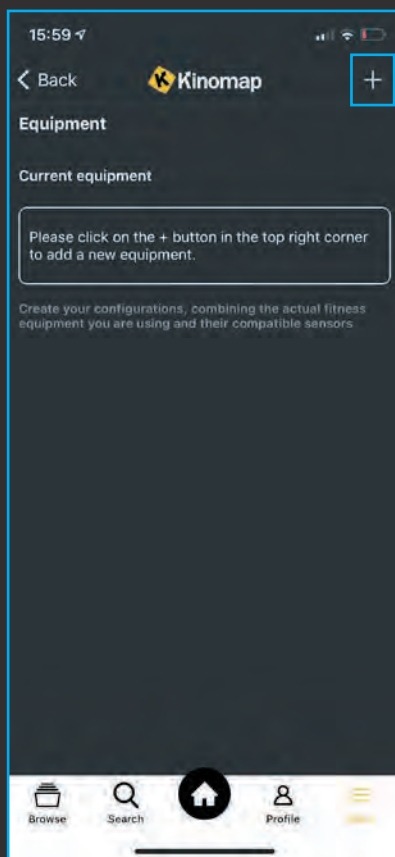

# 03

Selecteer het **Roei**-pictogram.



# 04

Selecteer het **Bluefin Fitness**-pictogram.

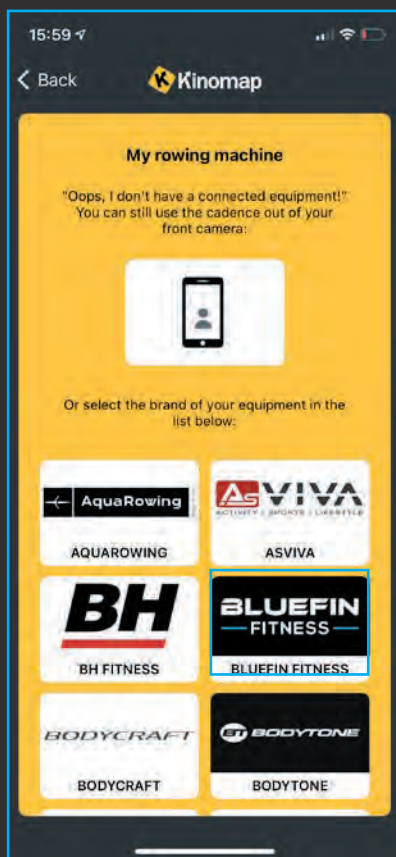

## 05

Selecteer **Blade Aqua M-1**.

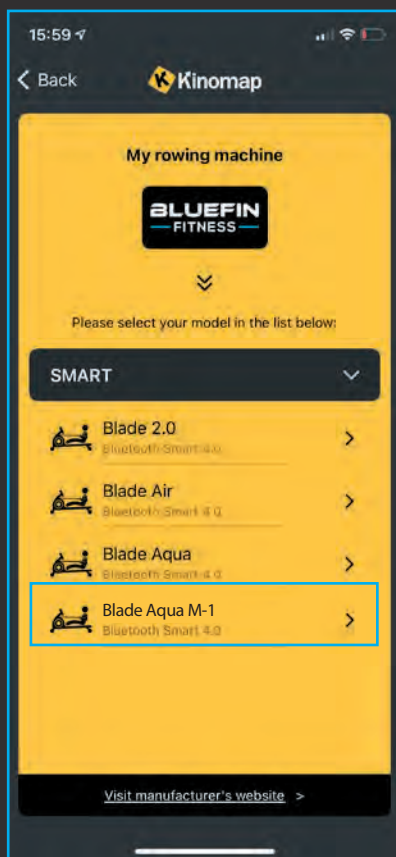

## 06

Voeg de **Blade Aqua M-1** toe en start je work-out.

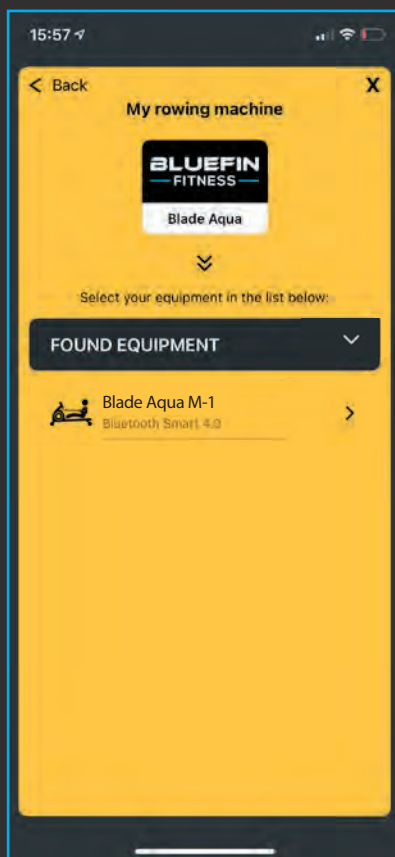

## OPWARMEN EN AFKOELEN

VOEG AAN ELKE WORK-OUT EEN OPWARMING EN AFKOEELINGS-FASE TOE MET REKOEFFENINGEN OM BLESSURES TE VOORKOMEN.

DE VOLGENDE REKOEFFENINGEN VERMINDEREN HET RISICO OP SPIERBLESSURES OF SPASMEN TIJDENS HET SPORTEN. ZORG ERVOOR DAT JE JE SPIEREN NIET OVERBELAST.

### SIDE BENDS

Breng één arm omhoog over je hoofd, beweeg daarbij je bovenlichaam in dezelfde richting en hou deze positie vast gedurende 10 tot 15 seconden. Ga langzaam weer rechtop staan. Herhaal dit 3 keer langs elke kant.

### TENEN AANRAKEN:

Buig langzaam naar voren vanuit je middel, ontspan je rug en schouders en rek je uit naar je tenen toe. Reik zo ver mogelijk naar beneden en houd dit 15 seconden vast. Ontspan en herhaal dit 3 keer.

### KALF-ACHILLESPEES STRETCH

Leun tegen een muur, plaats je linkerbeen voor je rechterbeen en je armen tegen de muur. Houd je rechterbeen recht en je linkervoet op de grond, buig het linkerbeen en leun naar voren door je heupen naar de muur te bewegen. Houd dit vast en herhaal 15 seconden op het andere been. Herhaal dit 3 keer voor elk been.

### QUADRICEPS STRETCH

Plaats één hand tegen de muur voor evenwicht. Reik achter je en trek je rechervoet omhoog. Breng je hiel zo dicht mogelijk bij je billen. Houd 10-15 seconden vast. Herhaal dit drie keer voor elke voet.

### BINNENSTE DIJ-STRETCH

Ga zitten met je voetzolen tegen elkaar en je knieën naar buiten gericht. Trek je voeten zo dicht mogelijk bij je lies. Duw je knieën voorzichtig naar de grond. Houd 15 seconden vast. Ontspan en herhaal dit 3 keer.

# ROEI-OEFENINGEN

## REGELMATIG GEBRUIK VAN DE ROEITRAINER:

- Verbetert je fysieke conditie, versterkt het hart, verbetert de bloedsomloop en traint alle belangrijke spiergroepen: de rug, taille, armen, schouders, heupen en benen.
- Versterkt je spieren & in combinatie met een caloriebeperkt dieet helpt de roeitrainer om gewicht te verliezen. Roeien is een uiterst efficiënte vorm van lichaamsbeweging..

## DE BASIS ROEISLAG

- Neem plaats op het zitje en maak je voeten met de riemen vast aan de pedalen. Pak de roeistang vast.
- Neem de startpositie in, leun naar voren met gestrekte armen en knieën gebogen, zoals weergegeven in **figuur 1**.
- Duw jezelf naar achteren en strek tegelijkertijd je rug en benen **Afb. 2**.
- Ga door totdat je iets naar achteren leunt en druk je ellebogen naar buiten **Afb. 3**. Keer dan terug naar fase 2 en herhaal.

## TRAINING

- Roeien vergt heel wat inspanning, begin dus met trainen op een lage weerstand en voor korte periodes als je een beginner bent. Naarmate je vordert, kun je de weerstand en tijd verhogen en nieuwe doelstellingen instellen.

We raden je aan om in het begin om de andere dag te trainen, zo'n 3 keer per week, om je lichaam de tijd te geven tussen de trainingen door te herstellen.

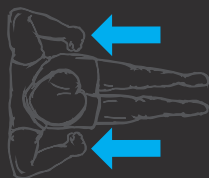

Afb. 1



Afb. 2



Afb. 3

# ROEI-OEFENINGEN

## ALTERNATIEVE ROEI-TRAININGEN

### ENKEL MET DE ARMEN ROEIEN

Deze roeistijl zal de spieren in je armen, schouders, rug en maag versterken. Ga zitten zoals in **figuur 4**, met gestrekte benen. Leun naar voren en pak de handgrepen vast. Leun geleidelijk achterover tot net voorbij de rechtzittende positie en trekt de handgrepen naar je borst. Keer terug naar de startpositie en herhaal.

### ENKEL MET DE BENEN ROEIEN

Deze oefening zal de spieren in je benen en rug versterken. Hou je rug en armen gestrekt, buig je benen totdat je de handvatten vast kunt grijpen in de startpositie, **afb. 7**. Gebruik je benen om je lichaam naar achteren te duwen, terwijl je de armen en rug recht houdt.

### SPIERVERSTEVIGING

De meest efficiënte manier om je spieren te verstevigen tijdens het roeien, is door een hoge weerstand in te stellen en ervoor te zorgen dat je geen blessures veroorzaakt door je spieren te overbelasten. We raden aan om altijd met een lichte weerstand op te warmen en af te koelen en om enkel in het laatste gedeelte van je training de weerstand te verhogen, wanneer je spieren goed zijn opgewarmd.

### GEWICHTSVERLIES

Hoe meer inspanning, hoe meer calorieën je verbrandt. Probeer de weerstand, duur en inspanning tijdens elke training geleidelijk te verhogen, dit zal je zeker helpen bij het afvallen.



Afb. 4



Afb. 5



Afb. 6



Afb. 7



Afb. 8



Afb. 9

## FABRIEKSGARANTIE

📧 DE BLUEFIN-GARANTIE DEKT ALLE TECHNISCHE FOUTEN AAN HET ARTIKEL. ALS JE EEN GARANTIECLAIM MOET INDIENEN, NEEM DAN CONTACT MET ONS OP VIA: [SUPPORT@BLUEFINTRADING.CO.UK](mailto:support@bluefintrading.co.uk)

### DE GARANTIE GELDT NIET IN GEVAL VAN:

- Algemene slijtage en sporen van gebruik
- Waterschade.
- Schade door onaangepast gebruik.
- Schade aan het chassis en krassen door onaangepast gebruik of vallen.
- Elektronische schade door onaangepast gebruik of vallen.
- De garantie begint bij ontvangst van de levering.
- Technische storingen zijn gedekt voor 12 maanden.

Als je vragen hebt over je garantie, kun je een e-mail sturen naar:  
[support@bluefintrading.co.uk](mailto:support@bluefintrading.co.uk)



William Vaughan, CEO  
Bluefin Trading Ltd.

## EU-CONFORMITEITSVERKLARING

Voor de meest recente en actuele EU-conformiteitsverklaring voor dit product, kun je terecht op: [www.bluefinfitness.com/manuals/bladeaqua\\_m1\\_DoC.pdf](http://www.bluefinfitness.com/manuals/bladeaqua_m1_DoC.pdf)

Importer Address:  
Bluefin Trading Ltd  
Keelham Farm  
Hebden Bridge  
UK  
HX7 8TG  
[www.bluefinfitness.com](http://www.bluefinfitness.com)



### ELEKTRISCH EN ELEKTRONISCH AFVAL

Gooi het toestel niet bij het huishoudelijk afval. De onderdelen van het toestel moeten afzonderlijk worden gerecycleerd of verwijderd volgens de plaatselijke voorschriften. De netbeheerder kan ook alle afgedankte elektrische en elektronische apparatuur aan het einde van hun levensduur inleveren bij de fabrikant. Kosten gemaakt voor transport naar de fabrikant zijn ten laste van de eigenaar van de afgedankte elektrische en elektronische apparatuur.



### RICHTLIJNEN INZAKE BATTERIJEN

Gooi batterijen niet bij het huishoudelijk afval. Recycleer of gooi batterijen op een veilige manier weg in overeenstemming met de lokale wetgeving. Alle door de fabrikant of distributeur geleverde batterijen kunnen aan het einde van hun levensduur worden teruggestuurd voor recyclage en veilige verwijdering. Kosten voor transport naar de fabrikant of distributeur zijn voor rekening van de eigenaar van de batterijen.



### RECYCLAGE VAN VERPAKKINGSMATERIALEN

Gooi de verpakking niet bij het huishoudelijk afval. Alle verpakkingsmaterialen kunnen veilig worden gerecycleerd volgens de lokale wetgeving.

# BLADE AQUA



M-1 WATER RESISTANCE ROWER

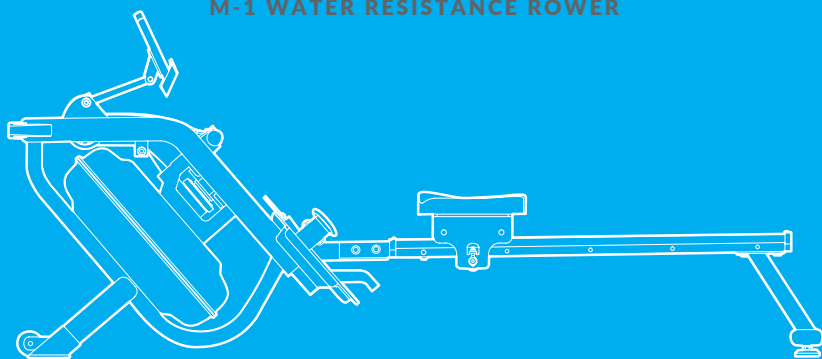



## VÄLKOMMEN TILL BLUEFIN FITNESS COMMUNITY

BÄSTA KUND,

TACK FÖR ATT DU HAR VALT BLUEFIN FITNESS RODDMASKIN BLADE AQUA M-1. FÖR ATT DU SKA FÅ STÖRSTA MÖJLIGA NYTTA OCH GLÄDJE AV DIN RODDMASKIN ÄR DET VIKTIGT ATT ALLA SOM ANVÄNDER UTRUSTNINGEN FÖRST LÄSER IGENOM DEN HÄR MANUALEN NOGGRANT OCH ÄR INFÖRSTÅDDA MED INNEHÅLLET.

BLUEFIN FITNESS TAR INGET ANSVAR FÖR SKADOR TILL FÖLJD AV FELAKTIG ELLER OLÄMPLIG ANVÄNDNING.

VI HOPPAS ATT DU GILLAR ATT ANVÄNDA DIN NYA RODDMASKIN BLADE AQUA M-1. OM DU ÄR INTRESSERAD AV ATT LÄSA MER OM ANDRA PRODUKTER I VÅRT VÄXANDE SORTIMENT AV TRÄNINGSMASKINER FÅR DU GÄRNA BESÖKA VÅR HEMSIDA: [BLUEFINFITNESS.COM](https://www.bluefinfitness.com) OCH FÖLJA OSS PÅ SOCIALA MEDIER:

**FACEBOOK** [FACEBOOK.COM/BLUEFINFITNESS](https://www.facebook.com/bluefinfitness)

**INSTAGRAM** [@BLUEFINFITNESS](https://www.instagram.com/bluefinfitness)

**TWITTER** [@BLUEFIN\\_FITNESS](https://twitter.com/bluefin_fitness)

**LINKEDIN** [LINKEDIN.COM/BLUEFIN-FITNESS](https://www.linkedin.com/company/bluefin-fitness)

HÄLSNINGAR FRÅN TEAMET PÅ BLUEFIN FITNESS.

## SÄKERHETSFÖRESKRIFTER

**i** SOM NÄMNTS OVAN ÄR DET VIKTIGT ATT ALLA SOM ANVÄNDER BLADE AQUA HAR LÄST IGENOM OCH ÄR INFÖRSTÅDDA MED INNEHÅLLET I DEN HÄR MANUALEN FÖRE ANVÄNDNING.

**VI REKOMMENDERAR ATT DU BEHÅLLER DEN HÄR MANUALEN FÖR FRAMTIDA BRUK.**

**Följande allmänna säkerhetsföreskrifter måste följas vid användning av Blade Aqua.**

- Rådgör alltid med läkare innan du påbörjar ett träningsprogram och ta hänsyn till eventuella medicinska eller fysiska tillstånd som kan innebära en risk för din hälsa och säkerhet, framför allt om du äter läkemedel för hjärtat, blodtrycket eller kolesterolnivån.
- Sluta omedelbart att träna om du upplever något av följande under träningen: skarp smärta, ett tryck över bröstet, oregelbunden puls, andnöd, yrsel eller illamående. Kontakta din läkare innan du fortsätter träna om du upplever något av symtomen ovan.
- Håll alltid barn och djur borta från roddmaskinen. Den är endast avsedd att användas av vuxna.
- Placera utrustningen på en stabil, jämn och plan yta, helst på en vadderad matta för att skydda golvet. Se alltid till att det är minst 60 cm fritt utrymme kring utrustningen.
- Kontrollera att alla muttrar och bultar sitter ordentligt fast innan utrustningen används.
- Undersök utrustningen regelbundet för att upptäcka eventuella skador och/eller tecken på slitage för att bibehålla en säker användning.

- Om du upptäcker felaktiga komponenter vid monteringen av utrustningen, eller om utrustningen låter konstigt när den används, avbryt träningen omedelbart. Använd inte utrustningen igen förrän problemet har åtgärdats.
- Bär lämpliga träningskläder när du använder utrustningen. Undvik löst sittande kläder som kan fastna.
- Stick inte in fingrar eller lösa föremål i utrustningens rörliga delar.
- Högsta användarvikt för den här enheten är 150 kg.
- Flytta utrustningen försiktigt så att du inte skadar dig själv eller andra runt omkring dig. Be om hjälp vid behov.
- Placera inte utrustningen i extrema temperaturer eller förhållanden, inklusive på fuktiga platser, vilket kan orsaka korrosion och driftproblem.
- Den här utrustningen är endast avsedd för privat bruk inomhus. Den är inte avsedd för kommersiell användning.

**⚠ VARNING: OM DU ÄR ÖVER 45 ÅR ELLER HAR KÄNDA HÄLSOPROBLEM MÅSTE DU RÅDGÖRA MED DIN LÄKARE INNAN DU ANVÄNDER UTRUSTNINGEN.**

**BLUEFIN FITNESS TAR INGET ANSVAR FÖR PERSON- ELLER MATERIALSKADOR SOM UPPKOMMER VID ELLER GENOM ANVÄNDNING AV DENNA PRODUKT.**

## LISTA ÖVER MEDFÖLJANDE DELAR

**i** INNAN DU MONTERAR BLADE AQUA M-1, KONTROLLERA ATT ALLA FÖLJANDE DELAR FINNS MED:

**OBS! VISSA MINDRE KOMPONENTER KAN REDAN VARA FÖRMONTERADE PÅ STÖRRE KOMPONENTER FÖR ATT UNDERLÄTTA MONTERINGEN.**



**19 x1**



**20 x1**



**80 M8 x1**



**59 M8\*15 x4**



**61 M4\*12 x2**



**62 M8\*15 x4**



**68 M8\*15 x8**



**72 M6\*10 x2**



**66 M8\*65 x4**



**74 OD20\*ID8.5\*1.5 x8**

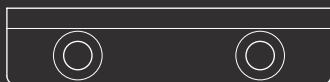

**40 x1**



**93 S5 x1**



**94 S13-17 x1**

# CHECKLISTA INFÖR MONTERING

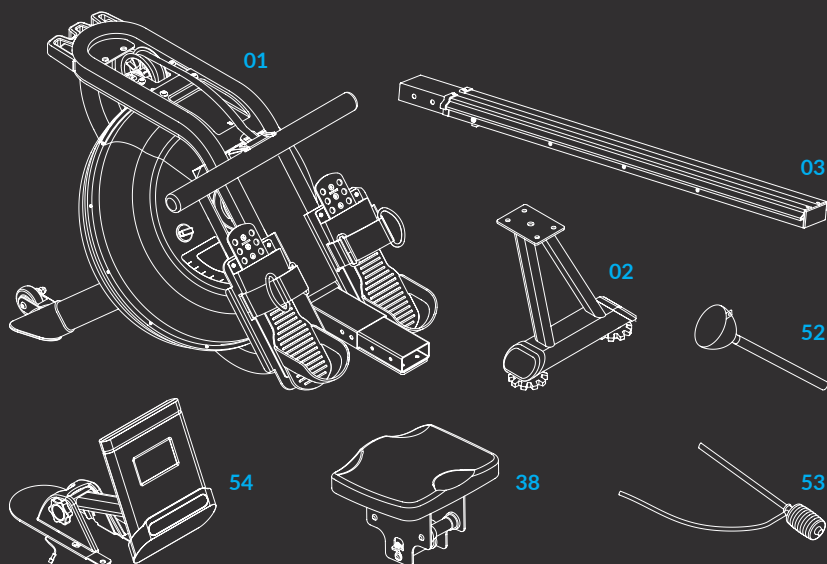

DEL	BESKRIVNING	ANTAL
01	Ram	x1
02	Bakre stödben	x1
03	Glidskena	x1
38	Sadel	x1
52	Tratt	x1
53	Pumphävert	x1
54	Träningsdator	x1

# 01

## MONTERINGSANVISNINGAR

ⓘ OBS! VI REKOMMENDERAR ATT TVÅ PERSONER MONTERAR UTRUSTNINGEN.

- Sätt fast sadeln 38 på glidskenan 03.
- Fäst stopplattan 40 med 2 st. platta stjärnskruvar 72.
- Fäst det bakre stödbenet 02 på glidskenan 03 med 4 st. brickor 74 och 4 st. sexkantskruvar 59.
- Dra åt med skiftnyckeln 94.



72 M6\*10 x2



59 M8\*15 x4



94 S13-17 x1



74 OD20\*ID8.5\*1.5 x4

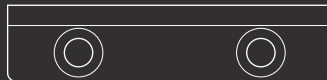

40 x1

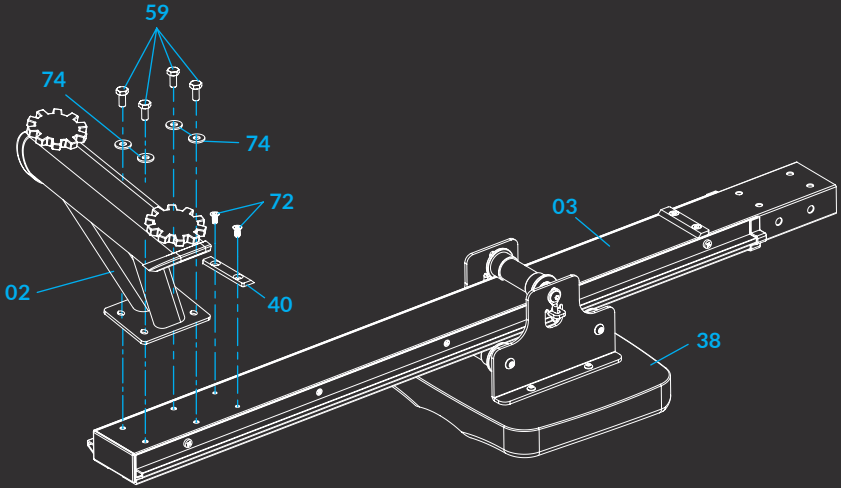

# 02

## MONTERINGSANVISNINGAR

- Fäst höger/vänster dekoration för skenan 19 och 20 med 02 st. stjärnskruvar 61 på glidskenan 03. Dra åt med skiftnyckeln 94.



19 x1



20 x1



61 M4\*12 x2



94 S13-17 x1

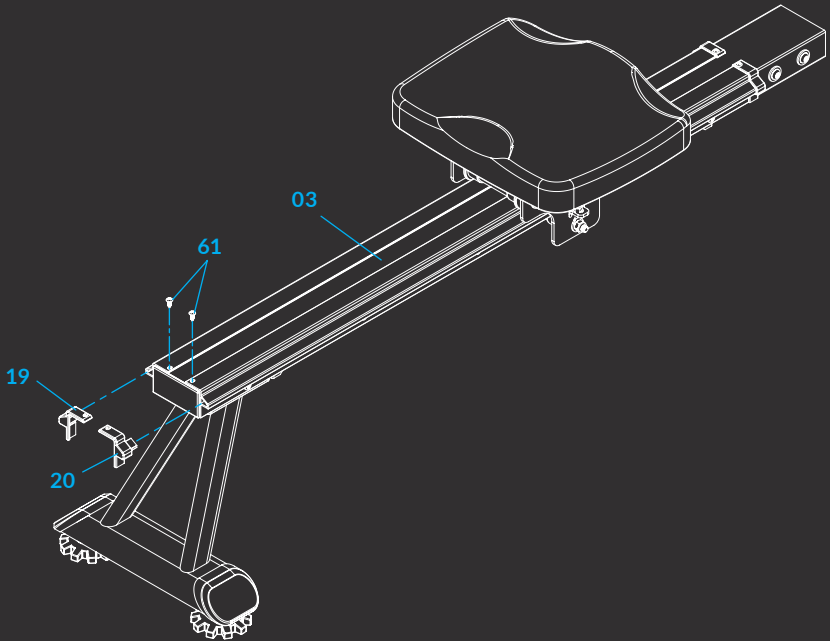

# 03

## MONTERINGSANVISNINGAR

① DRA FRAM SADELN 38 PÅ GLIDSKENAN 03 FÖRE MONTERING FÖR ATT FÖRHINDRA ATT DEN RÖR SIG UNDER MONTERING..

- Fäst glidskenan 03 på ramen 01 med hjälp av 4 st. brickor 74, 4 st. skruvar 68 och 4 st. platta skruvar 62.
- Sätt först i alla 8 skruvar löst i hålen och dra därefter åt med insexnyckeln 93.



62 M8\*15 x4



68 M8\*15 x4



74 OD20\*ID8.5\*1.5 x4



93 S5 x1

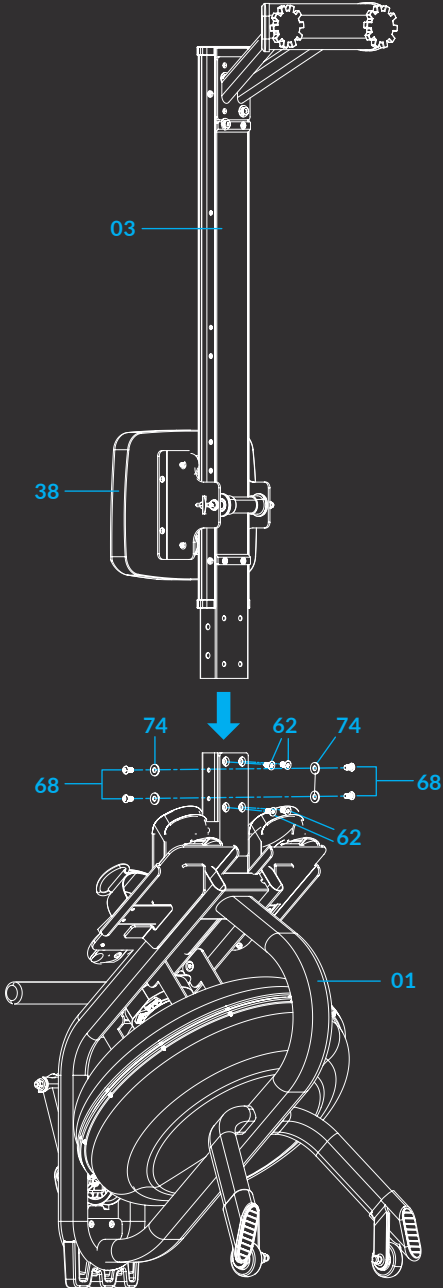

# 04

## MONTERINGSANVISNINGAR

- Fäst därefter stödet till konsolen 54 i ramen 01 och se till att kablarna sitter ihop. Dra därefter åt med 4 st. skruvar 68 och insexnyckeln 93.



66 M8\*65 x4



80 M8 x1



94 S13-17 x1



93 S5 x1



74 OD20\*ID8.5\*1.5 x2

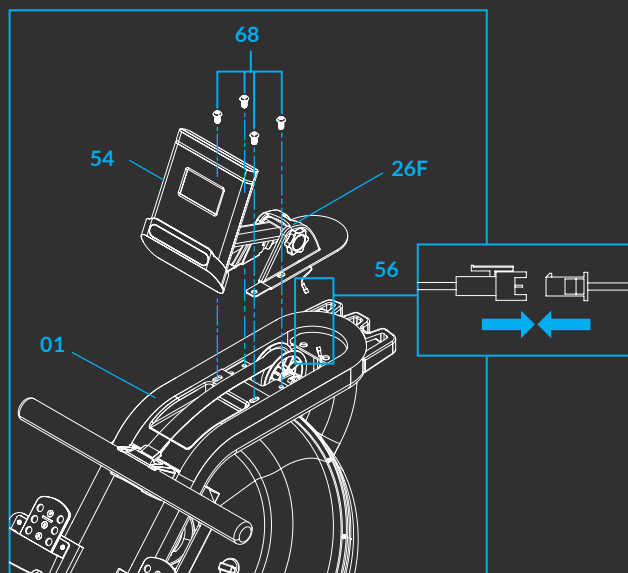

Lossa



dra åt

Lossa genom att vrida moturs 3 gånger,  
justera vinkeln på konsolen 54 och vrid  
därefter medsols för att dra åt.

# 05

## VATTENBEHÅLLARE

ANVÄND ALDRIG KLOR ELLER KLORIN FÖR ATT FYLLA PÅ VATTENBEHÅLLAREN, EFTERSOM DET SKADAR BEHÅLLAREN OCH UPPHÄVER GARANTIN.

TILLSÄTT 1 VATTENRENINGSTABLETT MED 2-3 MÅNADERS MELLANRUM, ELLER VID BEHOV. OM VATTNET BLIR GRUMLIGT BEHÖVER DET BYTAS UT.

DRICK INTE VATTNET FRÅN BEHÅLLAREN. AVLÄGSNA ALLTID VATTNET FRÅN BEHÅLLAREN MED HJÄLP AV PUMPHÄVERTEN OCH TA HAND OM DET PÅ ETT SÄKERT SÄTT.

### PÅFYLLNING OCH TÖMNING

- Avlägsna **proppen 50** från behållarens övre **skyddskåpa 24**.
- För att fylla behållaren med vatten, se **fig. A**.  
För in **tratten 52** i behållaren och använd en mugg eller **pumphäverten 53** och en hink för att fylla behållaren med vatten. Använd nivåmätaren på behållarens sida för att fylla på till önskad vattennivå.
- För att tömma behållaren, se **fig. B**.
- Placera en hink bredvid roddmaskinen och använd pumphäverten för att pumpa ut vattnet ur behållaren och ned i hinken.
- Sätt tillbaka **proppen 50** i behållarens övre **skyddskåpa 24**.  
Torka bort eventuellt vatten från ramen.

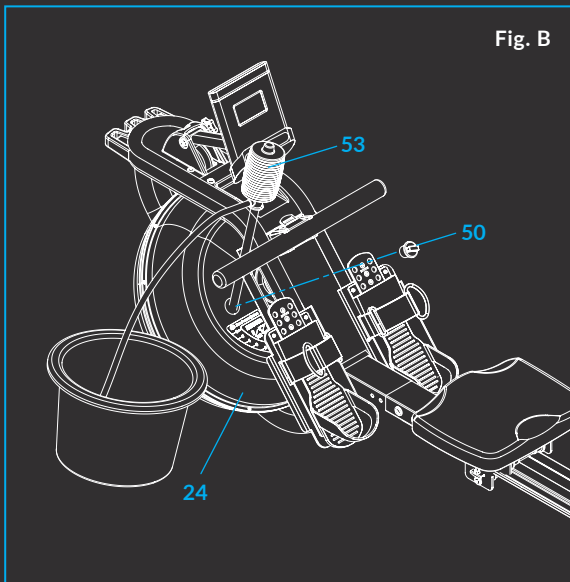
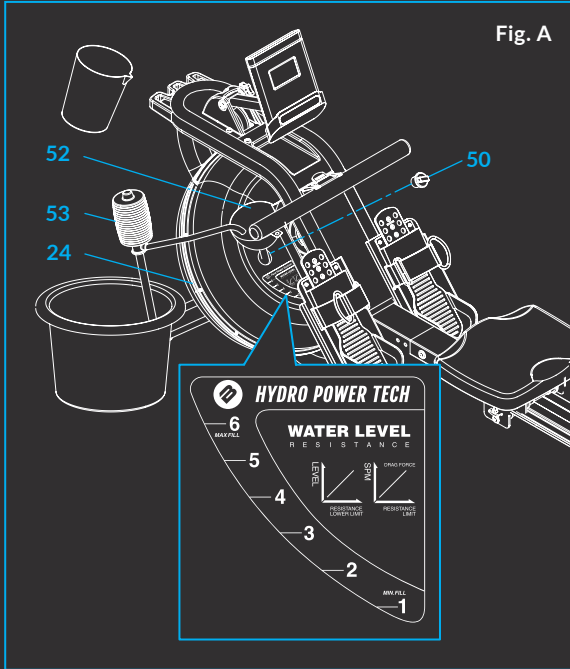

## VATTENBEHÅLLARE

### UNDERHÅLL OCH SKÖTSEL

- Vattenreningstabletter renar vattnet för användning under lång tid.
- Använd destillerat vatten för att fylla på behållaren.
- När du har tillsatt vattenreningstabletten i vattenbehållaren, börja ro för att röra om i vattnet så att tabletten löses upp.
- Varje vattenreningstablett innehåller cirka 167 mg natriumdikloroisocyanurat. Undvik kontakt med metallföremål för att undvika korrosion eller rost.

**⚠ VATTENRENINGSTABLETTER MEDFÖLJER INTE PRODUKTEN PÅ GRUND AV RESTRIKTIONER VID INTERNATIONELL FRAKT. KÖP VATTENRENINGSTABLETTER SEPARAT, ANTINGEN FRÅN EN TILLFÖRLITLIG ÅTERFÖRSÄLJARE LOKALT ELLER ONLINE.**



# 06

## FLYTT AV BLADE AQUA

- För att flytta roddmaskinen, lyft upp det bakre **stödbenet 02** tills **hjulen 18** på det främre stödbenet nuddar golvet.
- Med hjulen i golvet, rulla försiktigt roddmaskinen till önskad plats enkelt och smidigt.

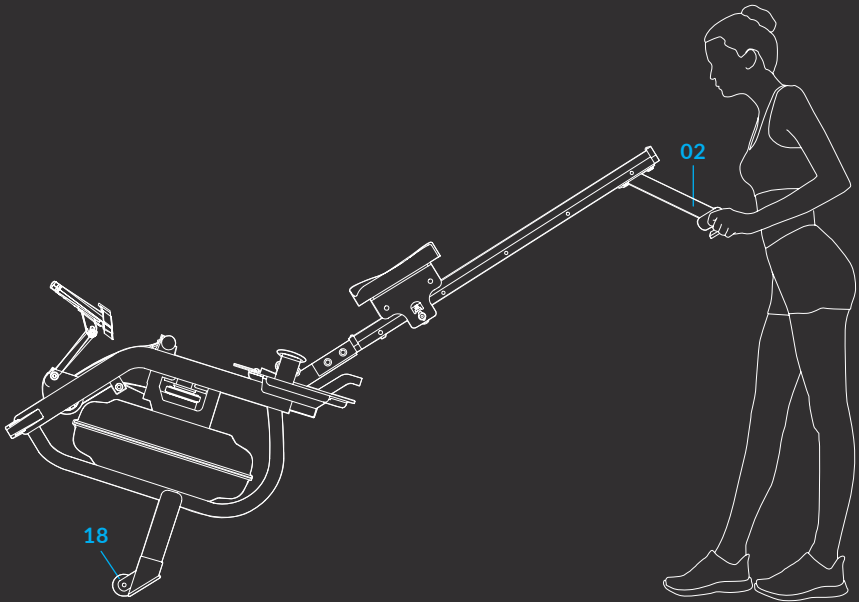

## STABILISERING AV BLADE AQUA

**⚠ FÖRSIKTIGHET! HÅLL HÄNDERNA BORTA FRÅN GLIDSKENAN NÄR DU JUSTERAR BLADE AQUA, EFTERSOM SADELN KAN ORSAKA SKADOR NÄR DEN RÖR SIG.**

- Om maskinen känns instabil vid användning, reglera **motståndsrattarna 23** under det bakre **stödbenet 02** för att stabilisera roddmaskinen.

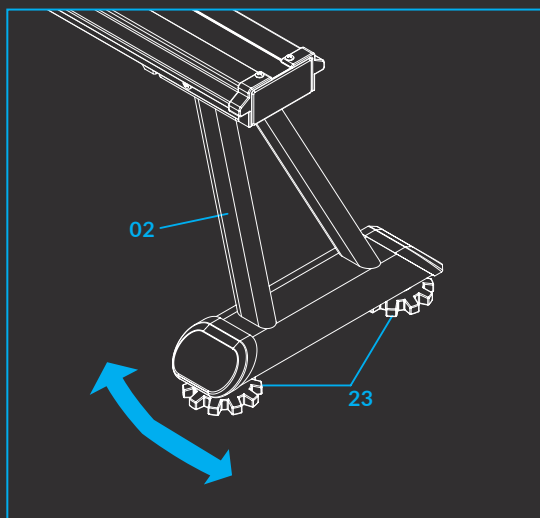

## FÖRVARING AV BLADE AQUA

 OBS! FLYTTA SADELN 38 TILL DEN FRÄMRE DELEN AV GLIDSKENAN 03 NÄR DU RESER RODDMASKINEN UPP, SÅ ATT SADELN INTE RÖR SIG UNDER FÖRFLYTTNINGEN.

 LYFT UPP GLIDSKENAN FÖRSIKTIGT FÖR ATT INTE SKADA DIG SJÄLV ELLER ANDRA I NÄRHETEN.

- När roddmaskinen inte används kan du spara plats genom att förvara den i upprätt position. Det gör du genom att lyfta upp det bakre **stödbenet 02** och ställa roddmaskinen på högkant.
- Om du inte kommer att använda roddmaskinen på över en månad måste vattenbehållaren tömmas innan du ställer undan maskinen.

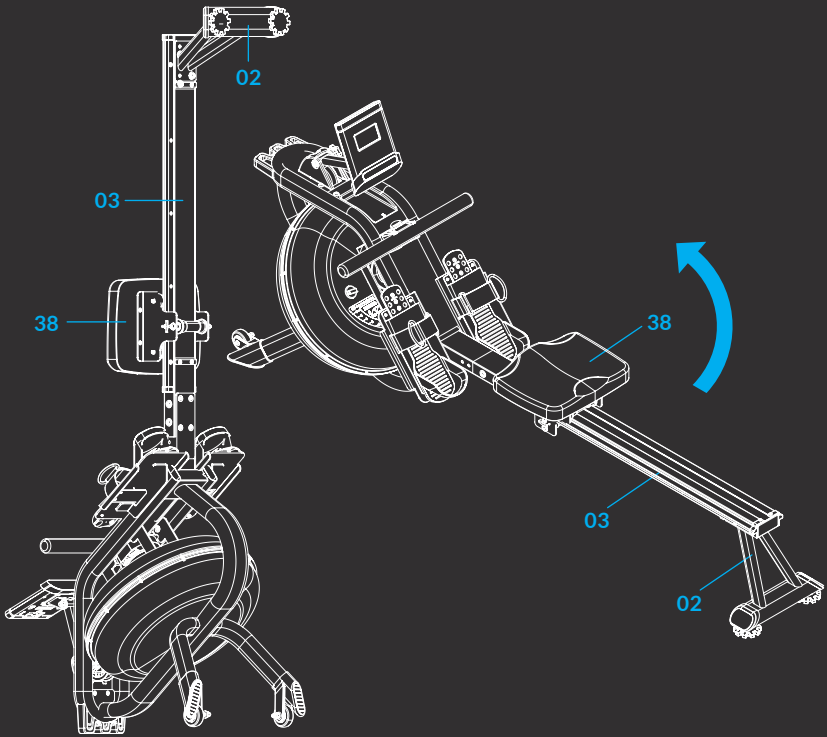



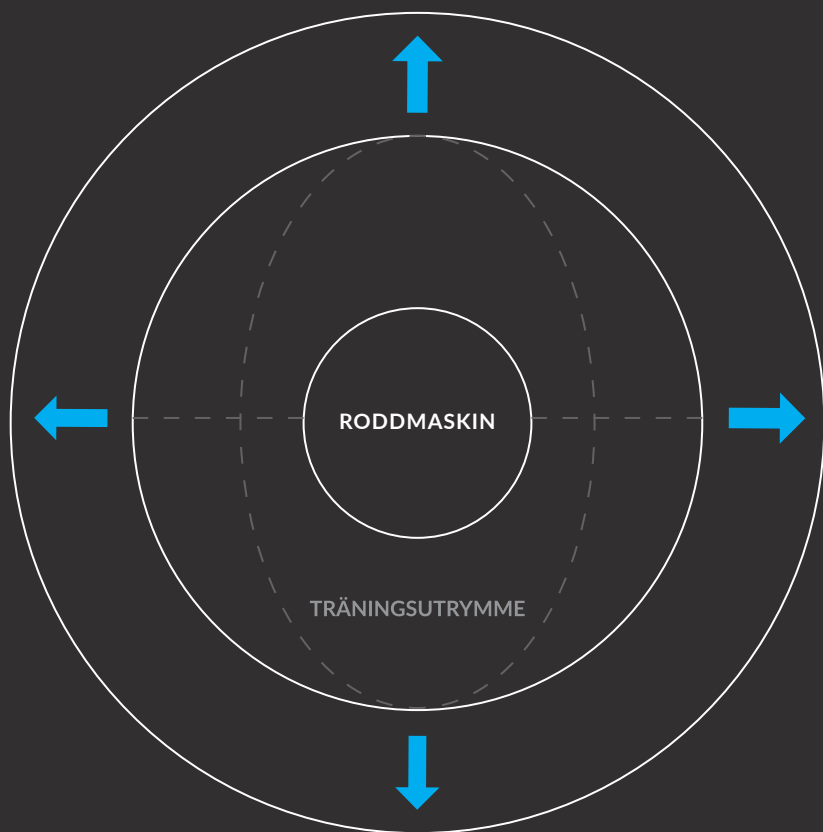

0,6 METER FRITT UTRYMME

# KONSOLFUNKTIONER

## FUNKTIONSKNAPPAR

<b>MODE</b>	Tryck ned för att välja funktion. Tryck ned i 2 sekunder för att återställa Time/Count/Distance och Calories
<b>SET</b>	För att ställa in Time/Count/Distance/Calories och Pulse när läget inte är Scan Mode.
<b>RESET</b>	Tryck ned för att återställa Time/Count/Distance/Calories och Pulse

## FUNCTIONS AND OPERATIONS

Tryck på **MODE** och välj **TIME**, så visas ordet "SCAN" på monitorns vänstra sida. Härifrån visas alla 6 funktioner på displayen i 6 sekunder åt gången: **TIME**, **COUNT**, **DISTANCE**, **CALORIE**, **RPM** och **PULSE**.

När önskad funktion visas på skärmen, tryck på knappen **MODE** för att välja den här funktionen och välj vilka parametrar du vill mäta under träningen.

<b>TIME</b>	Visar hur länge du har tränat.
<b>COUNT</b>	Visar hur många roddtag du har gjort.
<b>DISTANCE</b>	Visar sträckan du har tillryggalagt från start till mål.
<b>CALORIES</b>	Visar hur många kalorier du har bränt under träningen.
<b>RPM</b>	Visar antal roddtag per minut.
<b>PULSE</b>	Visar din nuvarande puls under träningen. <i>Du kan även bära det trådlösa pulsbandet för en mer exakt mätning av pulsen.</i>

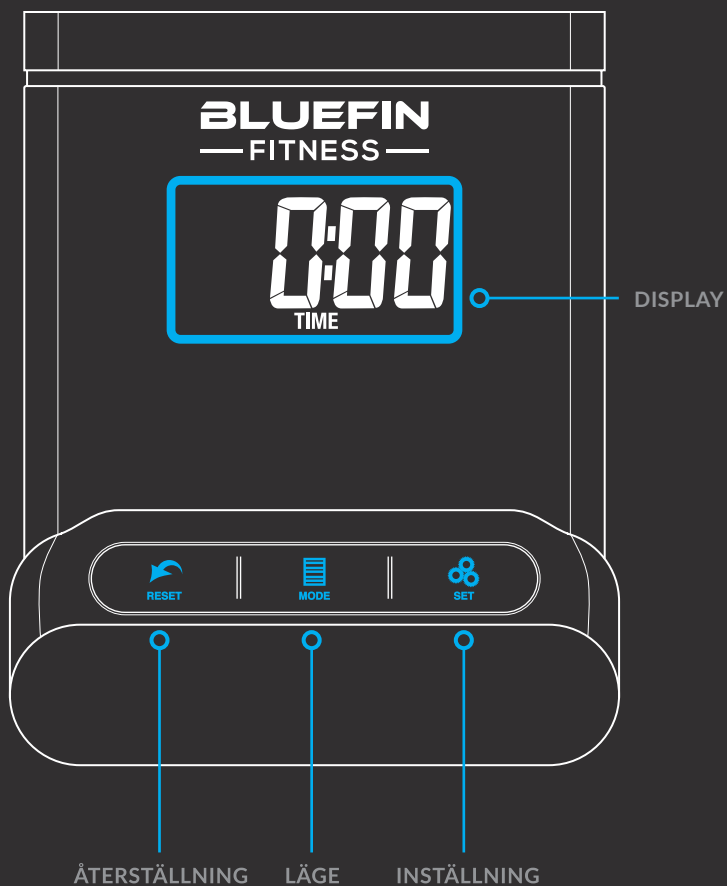

# ANVÄNDNING AV KONSOLEN

## INSTÄLLNING AV TRÄNINGSMÅL

Konsolen har fem träningslägen: Time, Count, Distance, Calories och Pulse. När du har valt träningsläge, tryck på knappen MODE för att få SCAN att sluta blinka på displayen.

**TIME** Tryck på knappen MODE, välj TIME och tryck på knappen SET för att ställa in hur länge du vill träna. Du kan trycka ned och hålla in SET-knappen för snabbare inställning. Släpp knappen när du har uppnått önskad tid. När du börjar ro kommer timern att starta och räkna ned från den inställda tiden. När du har uppnått träningsmålet kommer konsolen att pipa för att signalera att träningen har slutförts. Om du fortsätter träna efter detta kommer displayen automatiskt att börja räkna upp igen från noll.

**COUNT** Tryck på knappen MODE, välj COUNT och tryck på knappen SET för att ställa in antalet fullständiga roddtag du vill uppnå. Du kan trycka ned och hålla in SET-knappen för snabbare inställning. Släpp knappen när du har uppnått önskat antal roddtag. När du börjar ro kommer displayen att börja räkna ned från det inställda värdet. När du har uppnått träningsmålet kommer konsolen att pipa för att signalera att träningen har slutförts. Om du fortsätter träna efter detta kommer displayen automatiskt att börja räkna upp igen från noll.

**DISTANCE** Tryck på knappen MODE, välj DISTANCE och tryck på knappen SET för att ställa in den virtuella sträcka du vill uppnå. Du kan trycka ned och hålla in SET-knappen för snabbare inställning. Släpp knappen när du har uppnått önskad sträcka. När du börjar ro kommer displayen att börja räkna ned från det inställda värdet. När du har uppnått träningsmålet kommer konsolen att pipa för att signalera att träningen har slutförts. Om du fortsätter träna efter detta kommer displayen automatiskt att börja räkna upp igen från noll.

**CALORIE** Tryck på knappen MODE, välj CALORIES och tryck på knappen SET för att ställa in antalet kalorier du vill bränna. Du kan trycka ned och hålla in SET-knappen för snabbare inställning. Släpp knappen när du har uppnått önskat antal kalorier. När du börjar ro kommer displayen att börja räkna ned från det inställda värdet. När du har uppnått träningsmålet kommer konsolen

att pipa för att signalera att träningen har slutförts. Om du fortsätter träna efter detta kommer displayen automatiskt att börja räkna upp igen från noll.

**PULSE** Tryck på knappen MODE, välj PULSE och tryck på knappen SET för att ställa in den puls du vill uppnå under träningen. Du kan trycka ned och hålla in SET-knappen för snabbare inställning. Släpp knappen när du har \ uppnått önskad puls. När du börjar ro kommer displayen att börja räkna ned från det inställda värdet. När du har uppnått träningsmålet kommer konsolen att pipa för att signalera att träningen har slutförts. Om du fortsätter träna efter detta kommer displayen automatiskt att börja räkna upp igen från noll.

Du kan alltid ändra de inställda träningsmålen genom att trycka på knappen RESET för att rensa alla inställningar. Sedan kan du ställa in nya träningsmål genom att följa anvisningarna ovan.

**OBS! OM DISPLAYEN ÄR SVAG ELLER INTE VISAR NÅGRA SIFFROR, BYT DISPLAYENS BATTERIER.**

**KONSOLEN STÄNGS AV AUTOMATISKT NÄR DEN INTE HAR MOTTAGIT NÅGON SIGNAL PÅ 4 MINUTER.**

**MONITORN STARTAR AUTOMATISKT NÄR DU BÖRJAR ANVÄNDA RODDMASKINEN.**

**MONITORN BÖRJAR AUTOMATISKT ATT MÄTA DIN TRÄNING DIREKT NÄR DU BÖRJAR RO, OCH UPP TILL 4 SEKUNDER EFTER ATT DU HAR SLUTAT.**

FUNKTION:	SCAN	Var 6:e sekund
	TIME	0:00-99:59
	COUNT	0-9999 GÅNGER
	DISTANCE	0-9999 METER
	CALORIES	0.0-999,9 KCAL
	RPM	0-999 RODDTAG/MIN.
	PULSE	40-220 BPM (SLAG/MIN.)
BATTERITYP		2 ST. AA ELLER UM-3
DRIFTTEMPERATUR		0°C - +40°C
FÖRVARINGSTEMPERATUR		-10°C - +60°C

## TRÄNINGSPAPPEN KINOMAP

### ANSLUT TILL APPEN

- Sök efter KINOMAP i mobilens appbutik och ladda ned appen.
- När nedladdningen är klar, öppna KINOMAP-appen och registrera dina personuppgifter.
- Aktivera Bluetooth och kontrollera att Blade Aqua-konsolen är påslagen och i vaket läge.
- Synka Blade Aqua med KINOMAP-appen på följande sätt:



## 01

Tryck på More för att öppna sidan  
Equipment och välj  
Equipment Management.

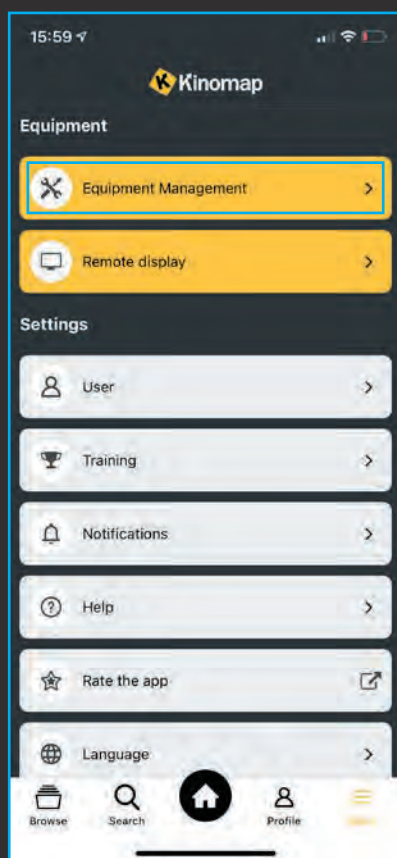

## 02

Tryck på ikonen +.

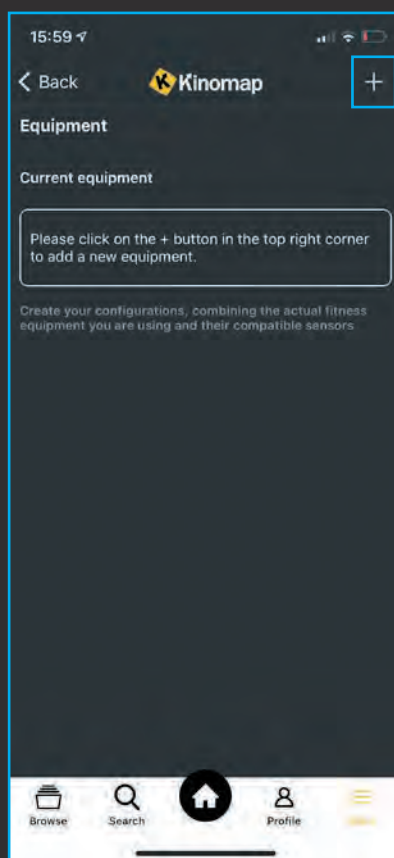

# 03

Välj roddikonen.



# 04

Välj Bluefin Fitness-ikonen.

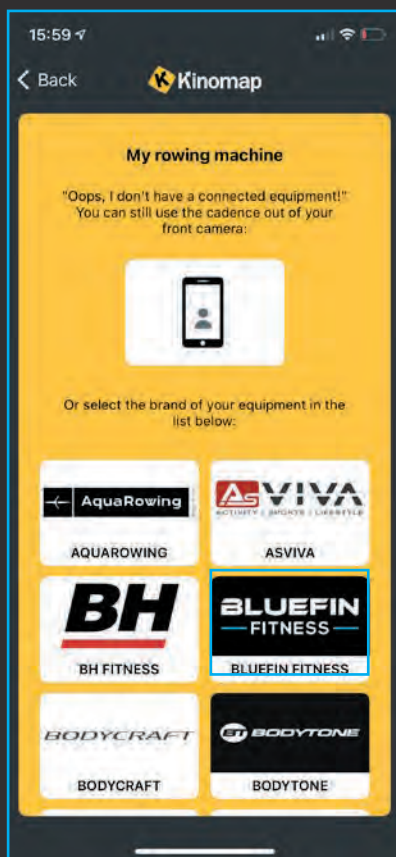

## 05

Välj Blade Aqua M-1.

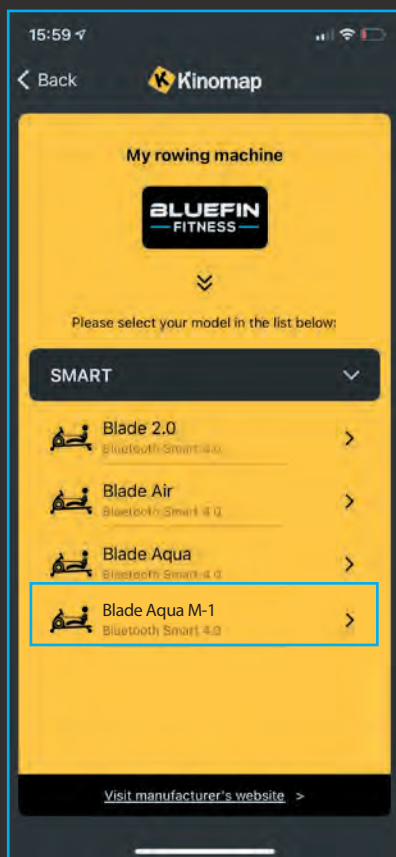

## 06

Lägg till din Blade Aqua M-1 för att slutföra inställningarna och börja träna.

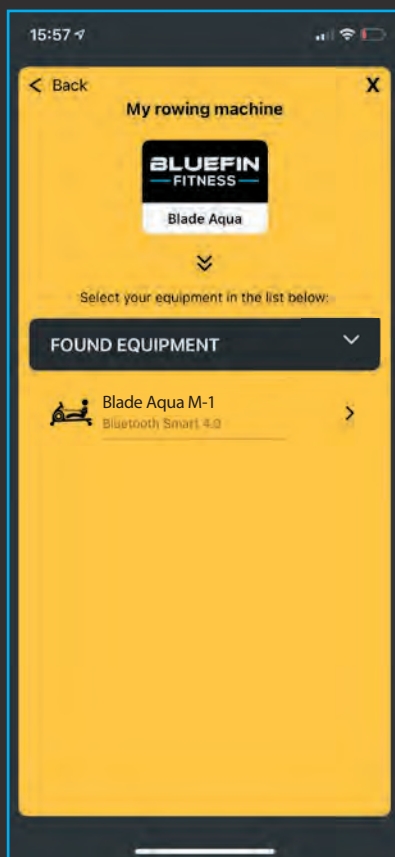

## UPPVÄRMNING OCH NEDVARVNING

FÖR ATT UNDVIKA SKADOR ÄR DET VIKTIGT ATT VÄRMA UPP OCH VARVA NED MED OLIKA STRETCHÖVNINGAR FÖRE OCH EFTER VARJE TRÄNINGSPASS.

VI REKOMMENDERAR FÖLJANDE STRETCHÖVNINGAR, SOM MINSKAR RISKEN FÖR MUSKELSKADOR OCH KRAMP UNDER TRÄNINGEN. STRETCHA ALDRIG MUSKLERNA FÖR HÅRT.

### P SIDOBÖJ

Sträck upp ena armen ovanför och förbi huvudet och låt överkroppen följa med i rörelsen. Håll i 10–15 sekunder och återgå därefter till ursprungspositionen. Upprepa 3 gånger på varje sida.

### NUDDA TÅRNA

Böj dig långsamt framåt från höften, slappna av i rygg och axlar och sträck dig mot tårna. Sträck dig så långt du kan och håll i 15 sekunder. Slappna av, upprepa 3 gånger.

### STRETCHA VADERNA

Luta dig mot en vägg med vänster ben framför det högra och armarna mot väggen. Håll högerbenet rakt och vänsterfoten mot golvet, böj därefter vänsterbenet och luta dig framåt genom att röra höfterna mot väggen. Håll i 15 sekunder och byt därefter ben. Upprepa 3 gånger på varje sida.

### STRETCHA FRAMSIDA LÅR

Luta vänsterhanden mot en vägg för bättre balans, sträck bak högerhanden och dra upp din högerfot. Dra foten så nära skinkan som möjligt. Håll i 10–15 sekunder. Upprepa 3 gånger för varje fot.

### STRETCHA INSIDA LÅR

Sitt med fotsulorna ihop och knäna utåt sidorna. Dra fötterna mot dig så nära du kan. Tryck försiktigt knäna mot golvet. Håll i 15 sekunder. Slappna av, upprepa 3 gånger.

# RODDÖVNINGAR

## GENOM ATT ANVÄNDA DIN RODDMASKIN REGELBUNDET:

- förbättras din allmänna fysiska kondition, du får starkare hjärta och bättre blodcirkulation samt tränar alla stora muskelgrupper: ryggen, magen, armarna, axlarna, höfterna och benen.
- får du starkare muskler, och i kombination med en hälsosam diet kan du även gå ned i vikt. Rodd är en extremt effektiv träningsform.

## GRUNDEN FÖR RÄTT RODDRÖRELSE

- Sitt på sadeln och sätt fast fötterna i pedalerna med hjälp av remmarna. Ta tag i roddhandtaget.
- Sätt dig i startpositionen genom att luta dig framåt med raka armar och böjda ben enligt **fig 1**.
- Tryck dig bakåt genom att sträcka ut ryggen och benen samtidigt, se **fig 2**.
- Fortsätt den här rörelsen tills du lutar dig lätt bakåt, i det här steget ska armarna fortsätta bakåt längs sidan av kroppen, se **fig 3**. Återgå därefter till steg 2 och upprepa.

## TRÄNING

- Rodd är en ansträngande träningsform, och det är därför bäst att börja med lågt motstånd och kortare pass om du är nybörjare. I takt med att du utvecklas kan du öka både motståndet och träningstiden efter dina behov och träningsmål.

Vi rekommenderar att du börjar träna ungefär varannan dag, cirka 3 dagar i veckan för att ge kroppen tid för återhämtning mellan passen.

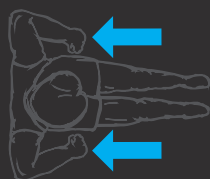

Fig 1



Fig 2



Fig 3

# RODDÖVNINGAR

## ALTERNATIVA RODDSTILAR

### RODD ENBART MED ARMARNA

Den här roddstilen stärker musklerna i armar, axlar, rygg och mage. Sitt som **fig. 4** visar med raka ben, luta dig framåt och fatta tag i handtaget. Gradvis och kontrollerat lutar du dig sedan bakåt till en lätt tillbakalutad position och fortsätter att dra handtaget mot bröstet. Återgå till startpositionen och upprepa.

### RODD ENBART MED BENEN

Den här övningen ger starkare muskler i ben och rygg. Med rak rygg och utsträckta armar, böj på benen tills du når handtaget i startpositionen, **fig. 7**. Använd benen för att skjuta kroppen bakåt, samtidigt som du håller armarna och ryggen rak.

## TRÄNA MUSKLERNA

Det effektivaste sättet att träna musklerna när du rör är att ställa in ett högt motstånd. För att undvika skador är det viktigt att du inte överbelastar musklerna. Vi rekommenderar alltid att värma upp och varva ned med lätt motstånd och öka motståndet mot slutet av träningen när musklerna är tillräckligt uppvärmda.

## VIKTMINSKNING

Ju mer du anstränger dig under roddträningen, desto fler kalorier bränner du. Sikta på att gradvis öka motståndet, träningslängden och ansträngningsnivån i varje pass, eftersom det är de här faktorerna som gör att du går ned i vikt.



Fig 4



Fig 5



Fig 6



Fig 7



Fig 8



Fig 9

## TILLVERKARGARANTI

📧 BLUEFINS GARANTI OMFATTAR EVENTUELLA TEKNISKA FEL HOS PRODUKTEN. OM DU BEHÖVER UTNYTTJA GARANTIN, KONTAKTA OSS VIA E-POST PÅ: [SUPPORT@BLUEFINTRADING.CO.UK](mailto:SUPPORT@BLUEFINTRADING.CO.UK)

### GARANTIN OMFATTAR INTE FÖLJANDE:

- Generellt slitage och märken till följd av användning.
- Vattenskador.
- Skador till följd av felaktig användning.
- Chassiskador och repor till följd av felaktig användning eller fall.
- Elektronikskador till följd av felaktig användning eller fall.
- Garantiperioden startar när du får leveransen.
- Tekniska fel täcks i 12 månader.

Om du har frågor om garantin får du gärna kontakta oss via e-post på: [support@bluefintrading.co.uk](mailto:support@bluefintrading.co.uk)



William Vaughan, CEO  
Bluefin Trading Ltd.

# EU-FÖRSÄKRAN OM ÖVERENSSTÄMMELSE

Den senaste, uppdaterade EU-försäkran om överensstämmelse för denna produkt hittar du på: [www.bluefinfitness.com/manuals/bladeaqua\\_m1\\_DoC.pdf](http://www.bluefinfitness.com/manuals/bladeaqua_m1_DoC.pdf)

Importer Address:  
Bluefin Trading Ltd  
Keelham Farm  
Hebden Bridge  
UK  
HX7 8TG  
[www.bluefinfitness.com](http://www.bluefinfitness.com)



## ELEKTRISKT OCH ELEKTRONISKT AVFALL

Släng inte denna produkt i hushållssoporna. Komponenterna i denna produkt måste återvinnas separat eller kasseras enligt lokala föreskrifter. Systemoperatören kan eventuellt även returnera elektriskt och elektroniskt avfall till tillverkaren vid livscykelns slut. Avgifter i samband med transport till tillverkaren betalas av ägaren till den elektriska och elektroniska utrustningen.



## BATTERIANVISNINGAR

Släng inte batterier i hushållssoporna. Återvinn eller kassera batterier på ett säkert sätt i enlighet med lokala föreskrifter. Batterier som levereras av tillverkaren eller distributören kan returneras i slutet av deras livscykel för återvinning och säker kassering. Avgifter i samband med transport till tillverkaren eller distributören betalas av ägaren till batterierna.



## ÅTERVINNING AV FÖRPACKNINGSMATERIAL

Släng inte förpackningar i hushållssoporna. Allt förpackningsmaterial kan återvinnas på ett säkert sätt i enlighet med lokala föreskrifter.

YOUR FITNESS JOURNEY



STARTS HERE



/BLUEFINFITNESS



@BLUEFINFITNESS



/BLUEFIN\_FITNESS



BLUEFIN FITNESS

**BLUEFINFITNESS.COM**  
BLUEFIN TRADING LTD  
KEELHAM FARM  
HEBDEN BRIDGE  
WEST YORKSHIRE (UK)  
HX7 8TG